

ergotron®

CareFit™ Slim Laptop Cart with Security Bracket

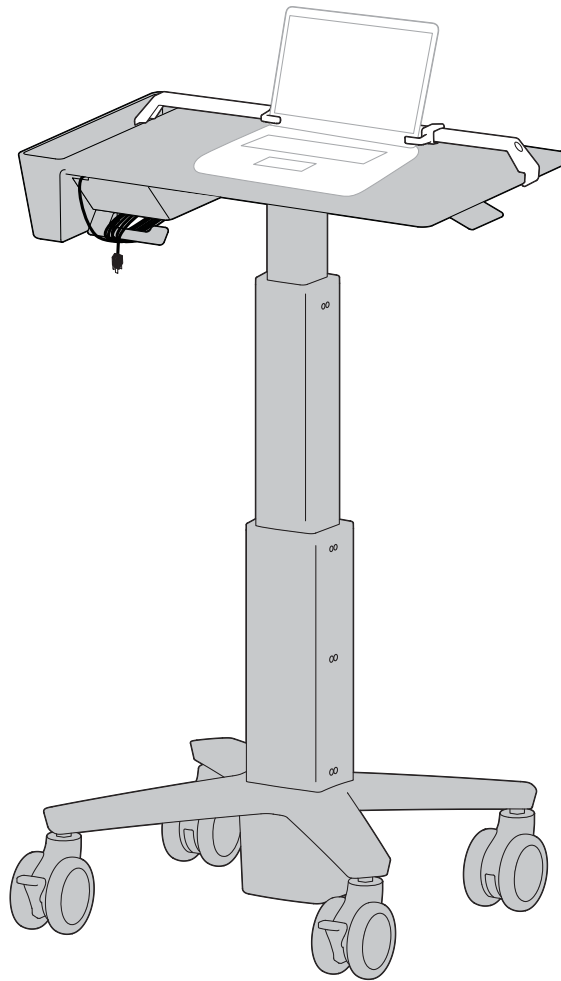

www.ergotron.com: English, Español, Français, Deutsch, Nederlands, Italiano, Svenska, 日本語, 汉语

www.ergotron.com | USA: 1-800-888-8458 | Europe: +31 (0)33-45 45 600 | China: 400-120-3051 | Japan: japansupport@ergotron.com



 **CAUTION**

TIPPING HAZARD

Lower cart below 41.5" (105 cm) before moving. Moving cart while raised too high could cause tipping resulting in equipment damage and/or personal injury.

829-362

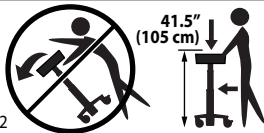

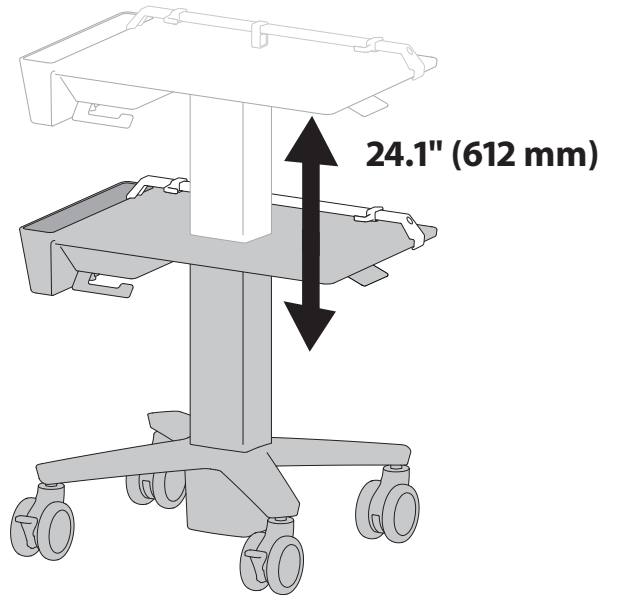
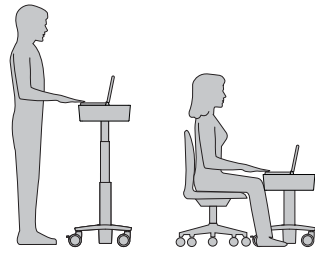
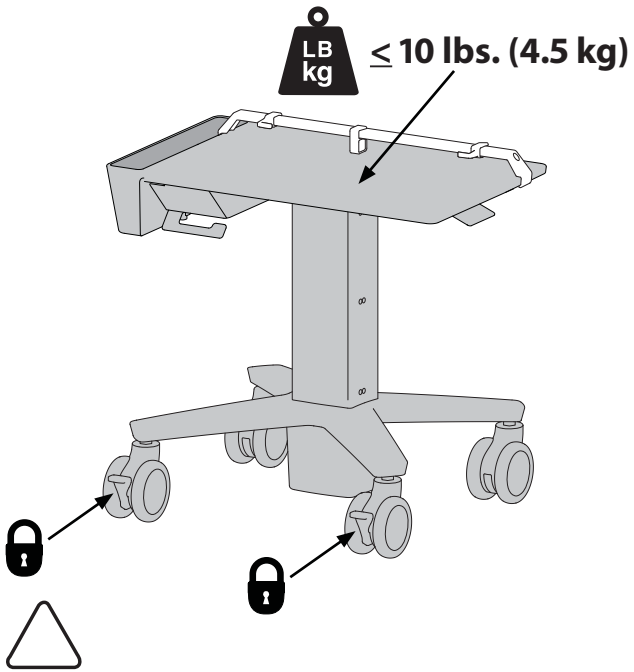

1x  4mm
 5 sided security wrench

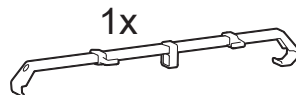
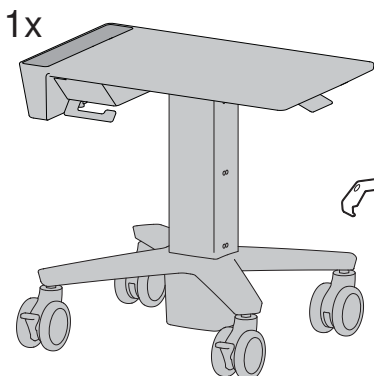
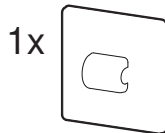

1

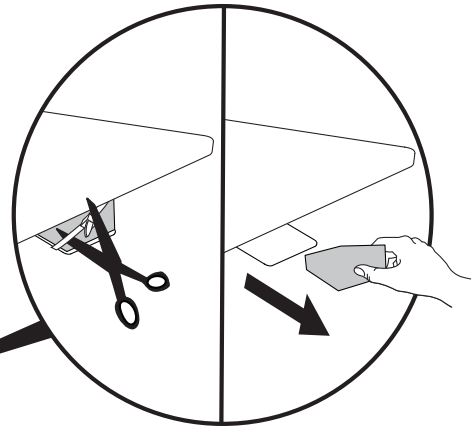
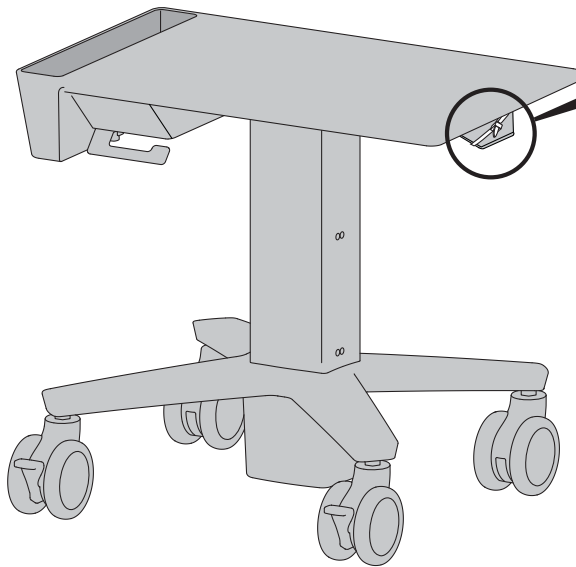

2

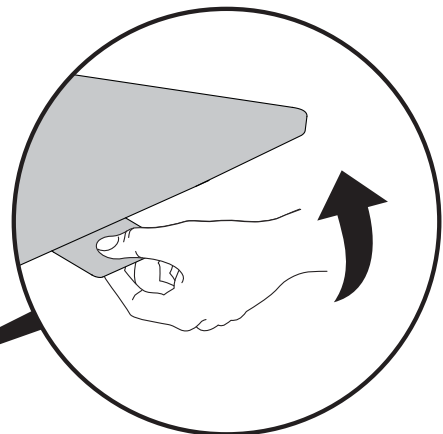
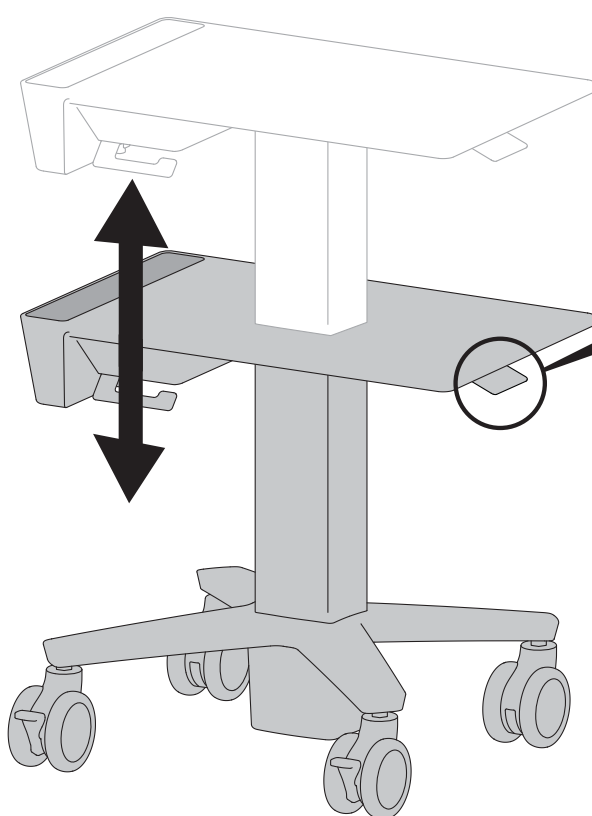

3



4mm
5 sided security wrench

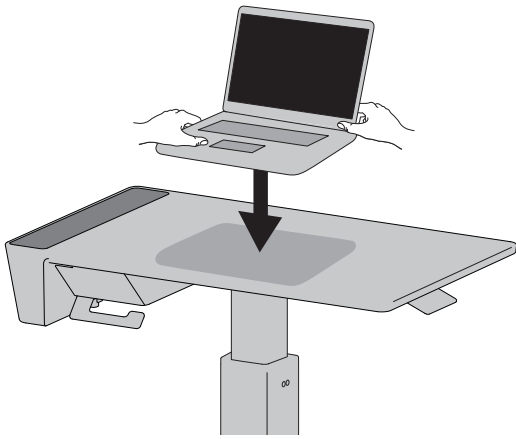

a

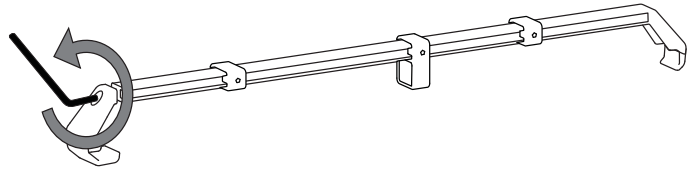

b

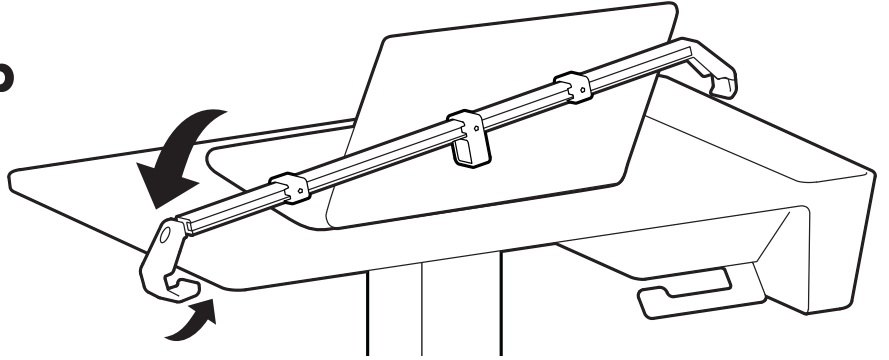

c

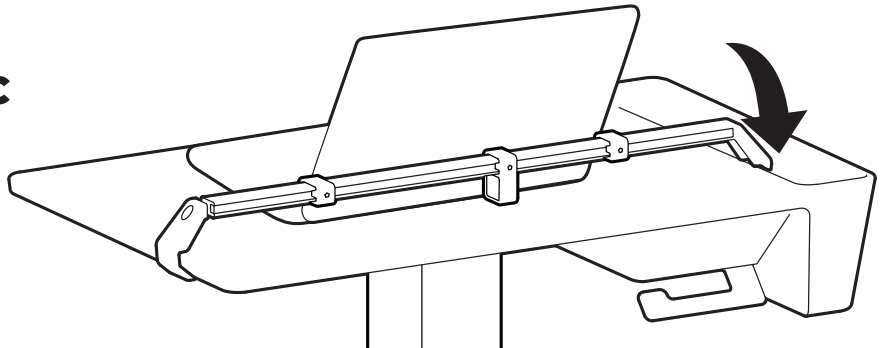

d

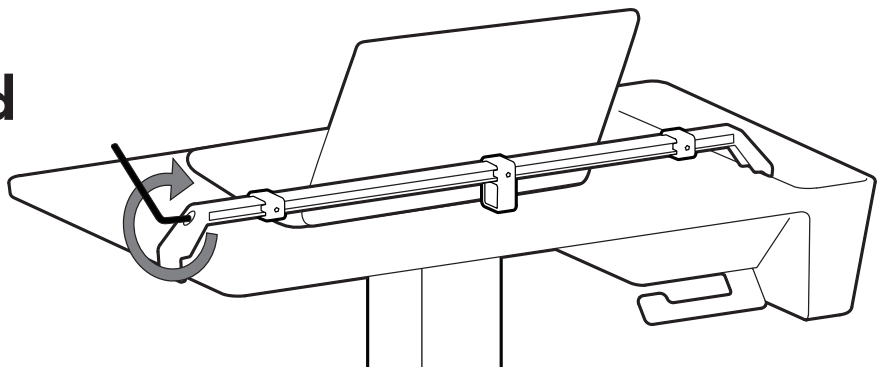

e

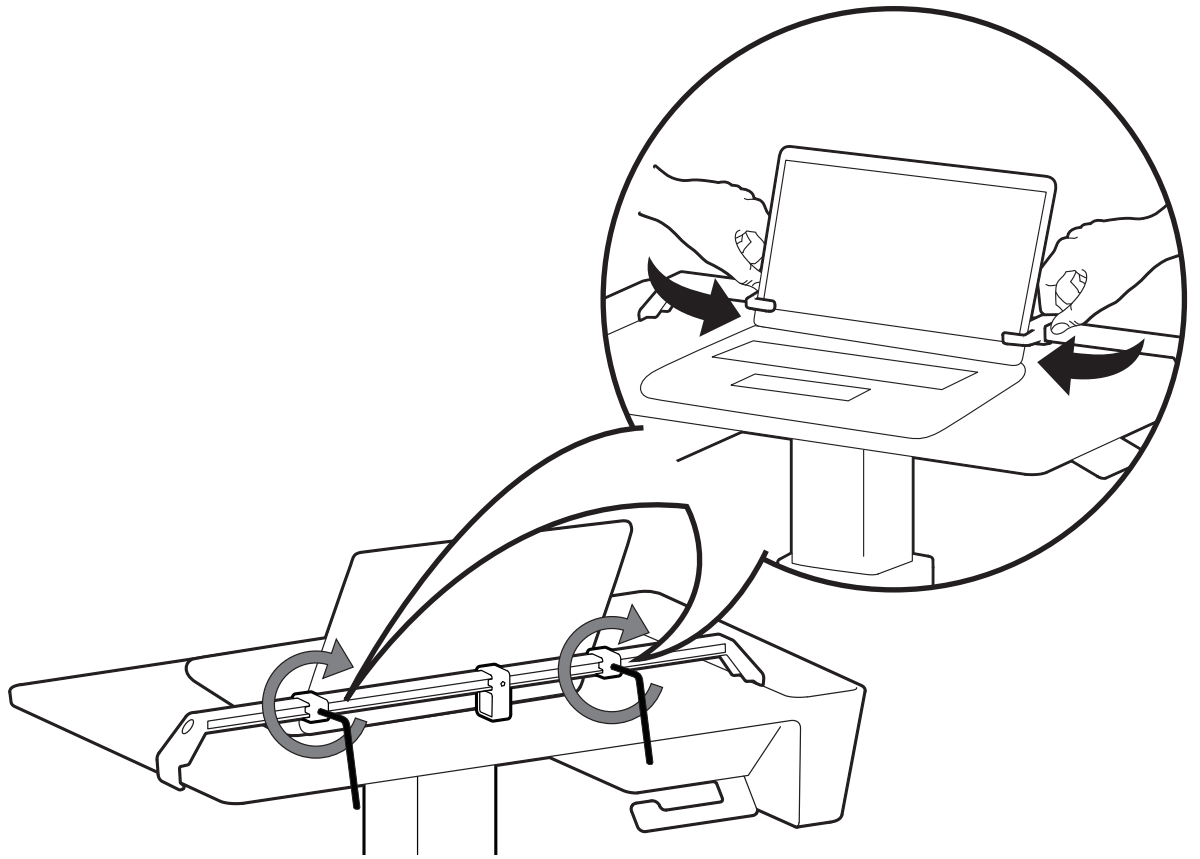

f

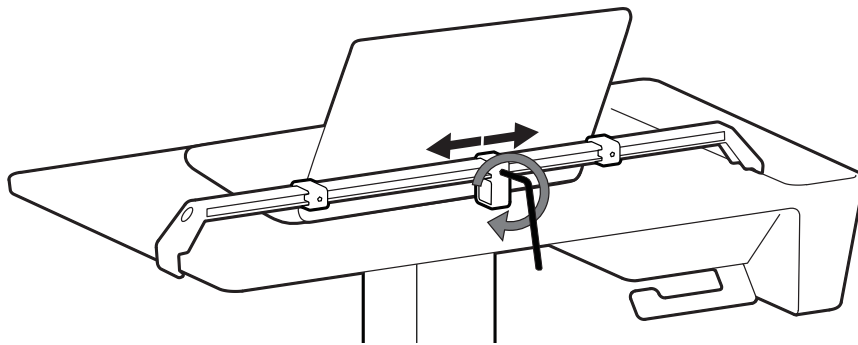

g

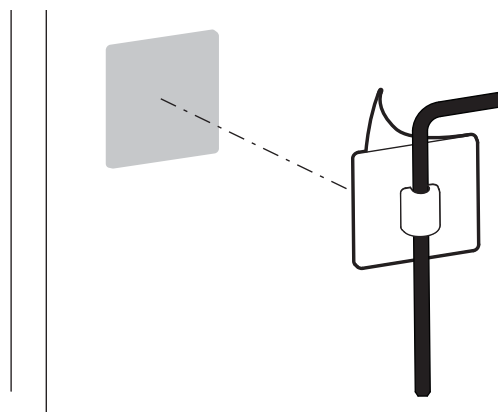

4

a

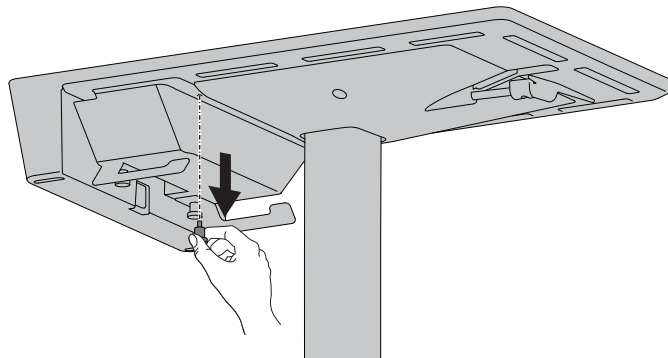

b

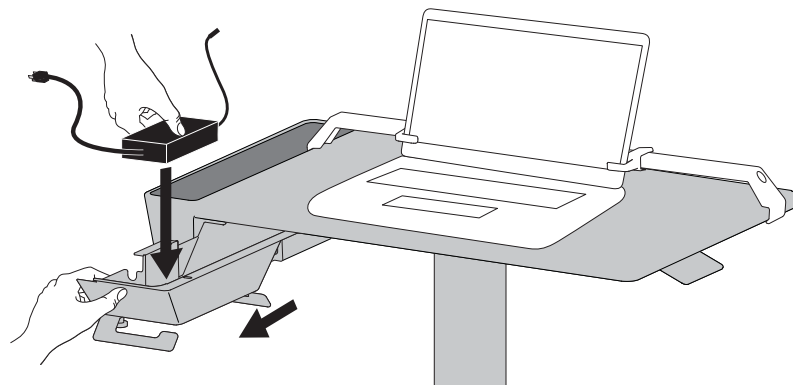

c

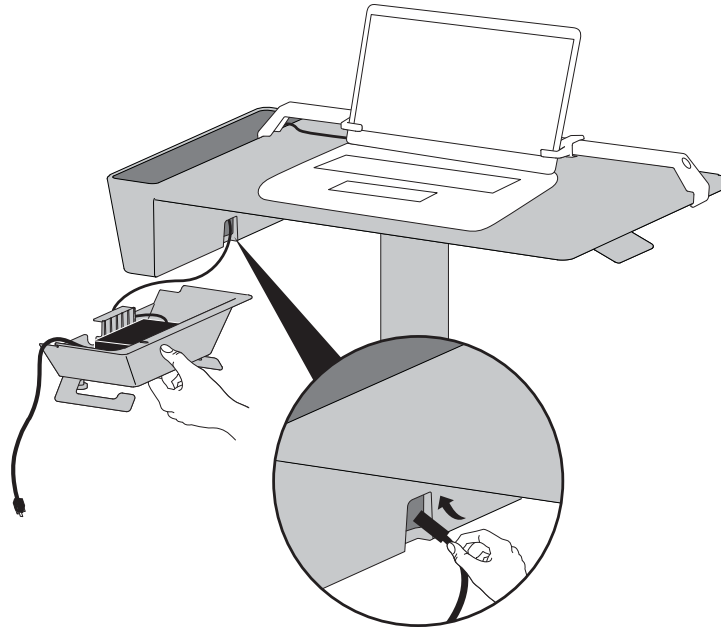

d

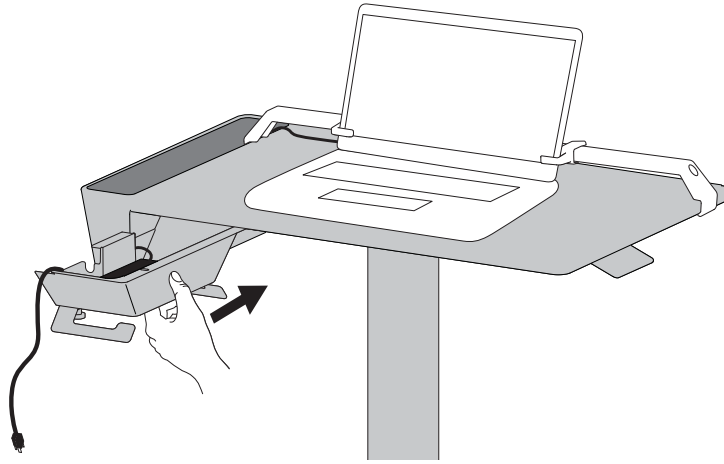

e

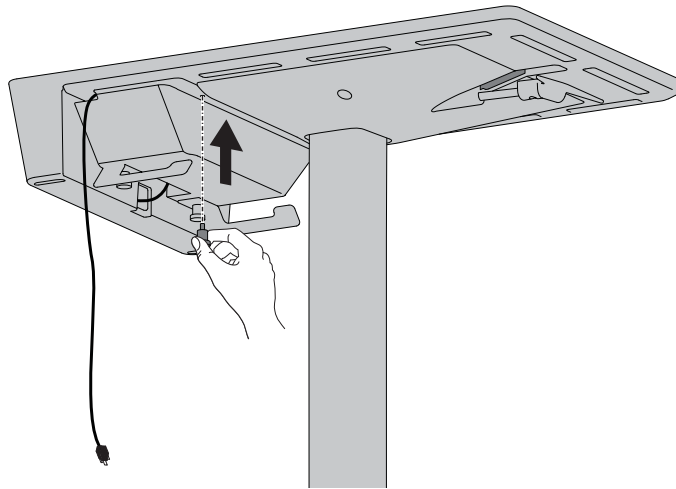

f

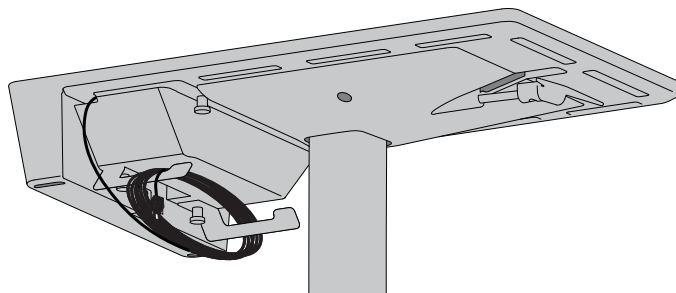

5

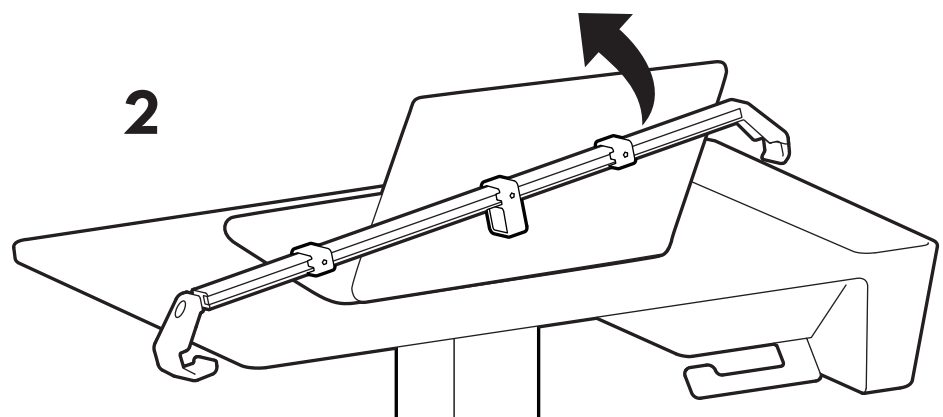
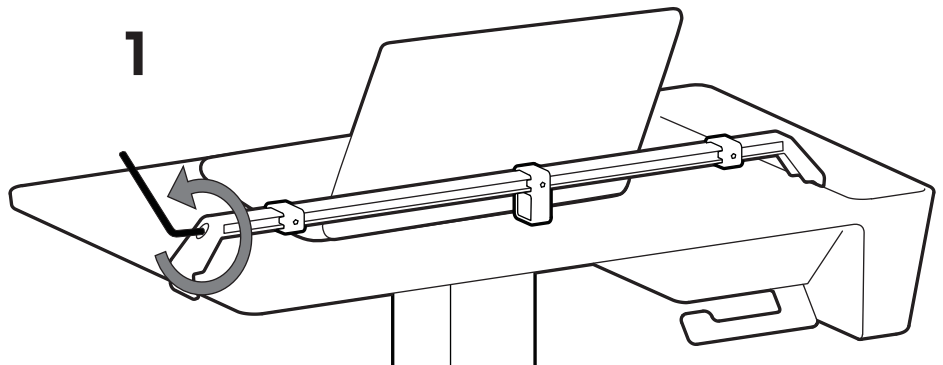
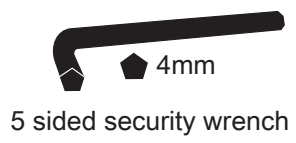
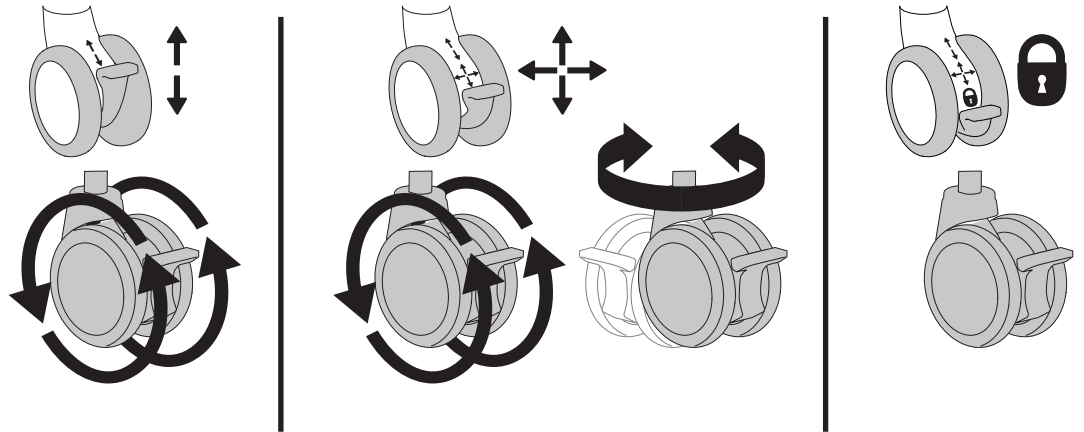
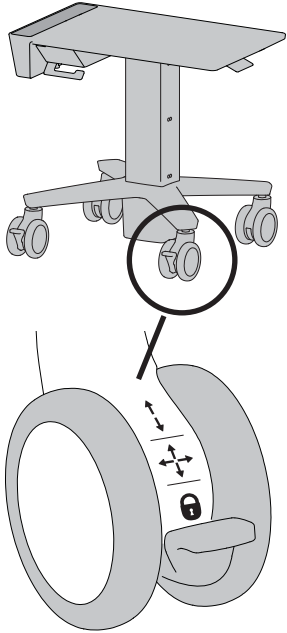

- EN** For the latest User Installation Guide please visit: www.ergotron.com
 For Warranty visit: www.ergotron.com/warranty
 For Service visit: www.ergotron.com
 For local customer care phone numbers visit: <http://contact.ergotron.com>
- ES** Para acceder a la última versión de la Guía de instalación para el usuario, ingrese a www.ergotron.com
 Para Garantía, visite: www.ergotron.com/warranty
 Para servicio, visite: www.ergotron.com
 Para conocer los números telefónicos locales de atención al cliente, visite: <http://contact.ergotron.com>
- FR** Pour la dernière version du Guide d'installation de l'utilisateur, visitez : www.ergotron.com.
 Pour la garantie, visitez: www.ergotron.com/warranty
 Pour le service client, visitez: www.ergotron.com
 Pour les numéros de téléphone du service client local, visitez : <http://contact.ergotron.com>
- DE** Die aktuellste Anleitung für die Montage durch den Benutzer finden Sie hier: www.ergotron.com
 Für Garantie Besuch: www.ergotron.com/warranty
 Für Servicebesuch: www.ergotron.com
 Örtliche Telefonnummern für den Kundendienst finden Sie hier: <http://contact.ergotron.com>
- JA** 最新のユーザー インストール ガイドは、www.ergotron.com でご確認いただけます。
 保証書をご覧ください: www.ergotron.com/warranty
 サービスをご覧ください: www.ergotron.com
 最寄りのカスタマー ケアの電話番号については、こちらをご覧ください: <http://contact.ergotron.com>
- ZH** 若需最新的用户安装指南，请访问：www.ergotron.com
 为保证参观：www.ergotron.com/warranty
 对于上门服务：www.ergotron.com
 若需当地客户服务电话号码，请访问：<http://contact.ergotron.com>

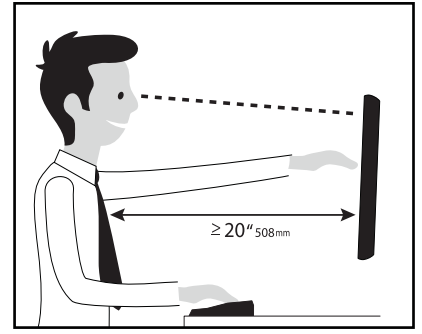

Learn more about ergonomic computer use at:
www.ergotron.com/ergonomics

- EN** NOTE: When contacting customer service, reference the serial number.
- ES** NOTA: Cuando se ponga en contacto con el servicio de atención al cliente, haga referencia al número de serie.
- FR** REMARQUE : Lorsque vous contactez le service à la clientèle, veuillez donner le numéro de série.
- DE** HINWEIS: Halten Sie bei der Kontaktaufnahme mit dem Kundendienst die Seriennummer griffbereit.
- JA** 注: カスタマー サービスにご連絡の際は、シリアル番号をお知らせください。
- ZH** 注: 联系客服时，请提供序列号。

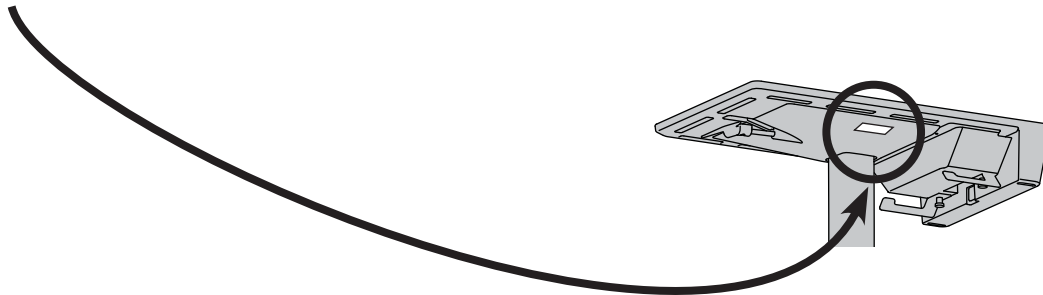

ergotron®

www.ergotron.com | USA: 1-800-888-8458 | Europe: +31 (0)33-45 45 600 | China: 400-120-3051 | Japan: japansupport@ergotron.com

© 2018 Ergotron, Inc. All rights reserved. CareFit™ and Constant Force™ are registered trademarks of Ergotron, Inc.

While Ergotron, Inc. makes every effort to provide accurate and complete information on the installation and use of its products, it will not be held liable for any editorial errors or omissions (including those made in the process of translation from English to another language), or for incidental, special or consequential damages of any nature resulting from furnishing this instruction and performance of equipment in connection with this instruction. Ergotron, Inc. reserves the right to make changes in the product design and/or product documentation without notification to its users. For the most current product information, or to know if this document is available in languages other than those herein, please contact Ergotron. No part of this publication may be reproduced, stored in a retrieval system, or transmitted in any form or by any means, electronic, mechanical, photocopying, recording or otherwise without the prior written consent of Ergotron, Inc., 1181 Trapp Road, Eagan, Minnesota, 55121, USA Patents Pending and Patented U.S. & Foreign. Ergotron is a registered trademark of Ergotron, Inc.

ergotron®

CareFit™ Slim Laptop Cart with Security Bracket

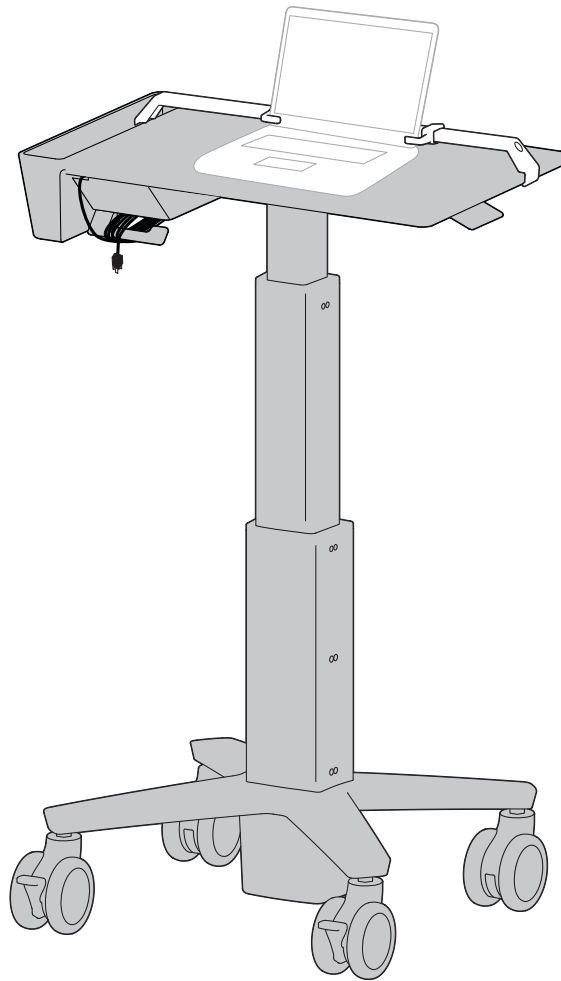

www.ergotron.com: English, Español, Français, Deutsch, Nederlands, Italiano, Svenska, 日本語, 汉语

www.ergotron.com | USA: 1-800-888-8458 | Europe: +31 (0)33-45 45 600 | China: 400-120-3051 | Japan: japansupport@ergotron.com

Overzicht symbolen voor gevaren





Deze symbolen waarschuwen gebruikers voor een veiligheidsomstandigheid waaraan aandacht besteed moet worden. Alle gebruikers moeten het belang van de volgende Veiligheidsgevaaren kunnen herkennen en begrijpen als zij daarmee geconfronteerd worden op het product of in de documentatie. Kinderen die de Veiligheidswaarschuwingen niet kunnen herkennen en niet op de juiste wijze daarop kunnen reageren mogen dit product niet gebruiken zonder toezicht van volwassenen!

Esame dei simboli di pericolo

Questi simboli avvisano gli utenti di una condizione di sicurezza che richiede attenzione. Tutti gli utenti devono essere in grado di riconoscere e comprendere il significato dei seguenti Pericoli per la sicurezza, se compaiono sul prodotto o all'interno della documentazione. I bambini non in grado di riconoscere e reagire nel modo appropriato ai Pericoli per la sicurezza non devono utilizzare questo prodotto senza la sorveglianza di un adulto!

Varningsymboler

För att informera användaren om säkerhetssituationer används följande symboler. Alla användare måste förstå innebörden av de nedanstående säkerhetsföreskrifter på produkten eller i dokumentationen. Barn som inte förstår säkerhetsföreskrifter skall inte använda denna produkt utan vuxen översyn.

Symbol Simbolo Symbol	Woordsignaal Indicazione di avvertenza Signalord	Gevarenniveau Livello di pericolo Varningsnivå
	LET OP NOTA OBS	EEN OPMERKING geeft aan dat er belangrijke informatie is die u helpt dit product beter te gebruiken. Le NOTE contengono informazioni importanti per un uso migliore del prodotto. OBS indikerar viktig information som hjälper dig att använda produkten bättre
	VOORZICHTIG ATTENZIONE VARNING	VOORZICHTIG geeft aan dat er mogelijke schade kan ontstaan aan de hardware of verlies van data en vertelt u hoe het probleem te vermijden. Il simbolo ATTENZIONE segnala un potenziale danno all'hardware o la perdita di dati e spiega come evitare il problema. VARNING påpekar möjlig skada på hårdvara eller dataförlust och talar om hur du kan undvika problemet.
	WAARSCHUWING AVVERTENZA FARA	Een WAARSCHUWING geeft aan dat er een kans is op beschadiging van apparatuur, verwonding van een persoon, of een dodelijk ongeluk. Le AVVERTENZE indicano la possibilità di danni agli oggetti, infortuni o morte. FARA varnar för möjlig egendomsskada, personskada eller livsfara.
	ELEKTRISCH ELETTRICO ELEKTRICITET	Elektrisch geeft een kans op een elektrisch gevaar aan, dat - als het niet vermeden wordt - verwonding van een persoon, brand en/of overlijden tot gevolg kan hebben. L'indicazione Elettrico indica un pericolo elettrico incombente che, se non evitato, potrebbe causare infortuni, incendi e/o morte. Elektricitet indikerar en förestående elektrisk fara som kan leda till personskada, brand och/eller livsfara.

Veiligheid Sicurezza Säkerhet



Belangrijk! U moet dit product bijstellen nadat de installatie voltooid is. Overtuig u ervan dat al uw apparatuur op de juiste wijze geïnstalleerd is op het product voordat u probeert bijstellingen uit te voeren. Dit product moet soepel en makkelijk bewegen door alle bewegingen en blijven staan waar u het zet. Als het te makkelijk of moeilijk beweegt of als het product niet in de gewenste posities blijft staan, volg dan de instructies voor het bijstellen om te zorgen voor soepele en makkelijke bewegingen. Afhankelijk van uw product en de bijstelling moet u mogelijk veel aan de schroeven en knoppen draaien om een verschil te merken. Elke keer als apparatuur toegevoegd of verwijderd wordt van dit product met als resultaat een verandering in het gewicht van de gemonteerde belasting, moet u deze stappen voor bijstelling opnieuw doorlopen om te zorgen voor een veilige en beste werking.

Importante! Al termine dell'installazione, sarà necessario regolare questo prodotto. Verificare che tutte le apparecchiature siano correttamente installate sul prodotto, prima di cercare di eseguire le regolazioni. Questo prodotto deve spostarsi in modo uniforme e scorrevole attraverso l'intero raggio di movimento, nonché restare fermo nel punto in cui viene collocato. Se gli spostamenti appaiono troppo agevoli o troppo difficoltosi, oppure se il prodotto non resta nelle posizioni previste, attenersi alle istruzioni sulla regolazione per ottenere spostamenti uniformi e scorrevoli. In base al prodotto e alla regolazione, è possibile che siano necessari molti giri per notare la differenza. Ogni volta che si aggiungono o tolgono apparecchiature dal prodotto, determinando una modifica nel peso del carico montato, occorre ripetere questi passaggi di regolazione, per garantire un funzionamento sicuro e ottimale.

Viktigt! Efter avslutad installation måste du justera produkten. Se till att all utrustning är installerad korrekt innan du påbörjar justeringen. Du ska lätt kunna flytta produkten över hela rörelseområdet och den ska stanna i den position du lämnar den. Om det är för lätt eller trögt att ändra positioner eller om produkten inte stannar i avsedd position, följ justeringsinstruktionerna för optimal positionsrärlighet. Det kan ta mer än en justering för att nå önskat beteende beroende på produkt och justering. Om du lägger till eller tar bort utrustning bör du justera produkten för den nya viktbelastningen. På så sätt bibehåller du en säker och behaglig arbetssituation.



Voorzichtig:

Om te voorkomen dat de snoeren mogelijk beklemd raken, dient u de instructies voor het leiden van de snoeren in dit handboek te volgen. Nalaten deze instructies te volgen kan de apparatuur beschadigen of persoonlijk letsel veroorzaken.

Attenzione:

Per evitare la possibilità di schiacciare i cavi, è importante seguire le istruzioni di instradamento dei cavi riportate nel presente manuale. La mancata osservanza delle presenti istruzioni può causare danni alle cose o infortuni personali.

Var aktsam:

För att undvika att kablarna kläms är det viktigt att följa kabeldragningsanvisningarna i denna handbok. Försummelse att följa dessa anvisningar kan leda till skador på utrustningen eller personskador.

CAUTION

TIPPING HAZARD

Lower cart below 41.5" (105 cm) before moving. Moving cart while raised too high could cause tipping resulting in equipment damage and/or personal injury.

829-362



Kenmerken en specificaties
 Caratteristiche e dati tecnici
 Funktioner och specifikationer

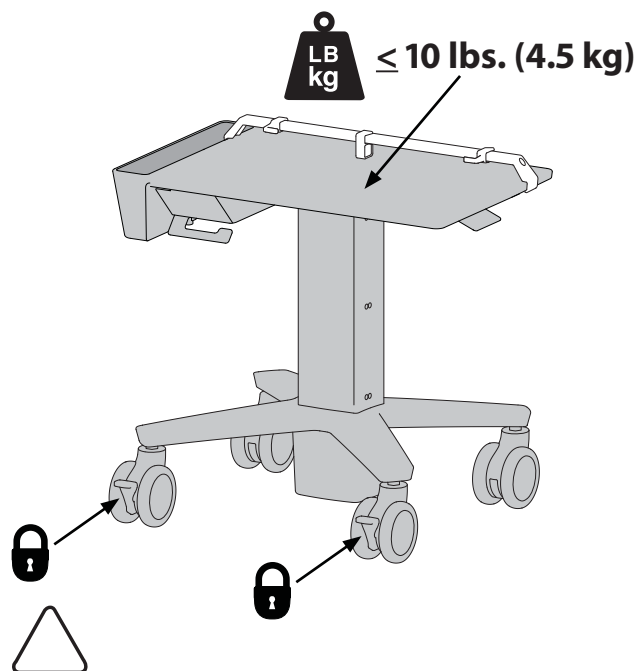

VOORZICHTIG: OVSCHRIJD DE MAXIMUM OPGEGEVEN
 GEWICHTSCAPACITEIT NIET. DIT KAN LEIDEN TOT ERNSTIGE
 VERWONDINGEN OF BESCHADIGING VAN BEZIT.

ATTENZIONE: NON SUPERARE LA CAPACITÀ DI CARICO MASSIMA
 INDICATA. POTREBBERO VERIFICARSI INFORTUNI O DANNI AGLI
 OGGETTI!

VARNING: ÖVERSKRID INTE MAXVIKTKAPACITETEN. DU KAN
 ORSAKA ALLVARLIG PERSON ELLER EGENDOMSSKADA

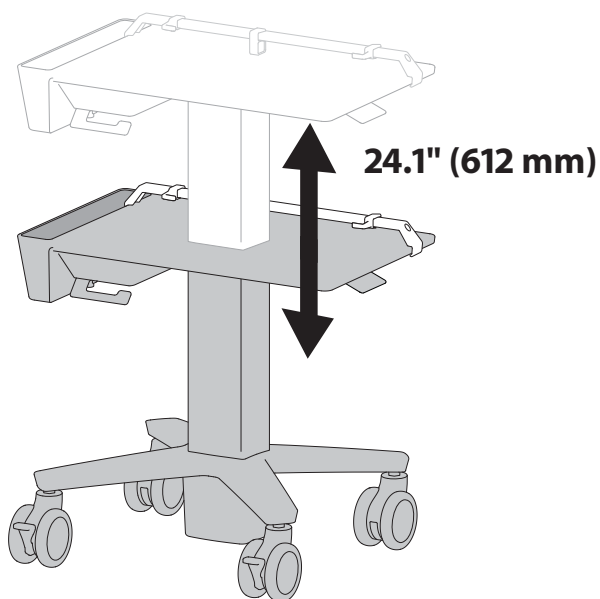
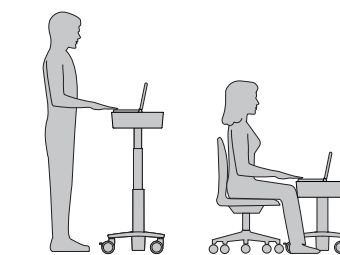

Onderdelen
 Componenti
 Komponenter

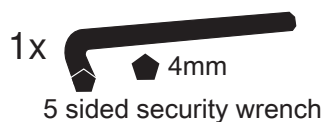

5 sided security wrench

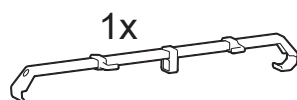
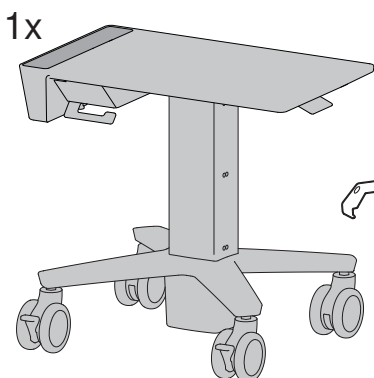
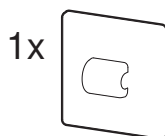

Benodigde gereedschappen
 Utensili necessari
 Verktvg som behövs



1

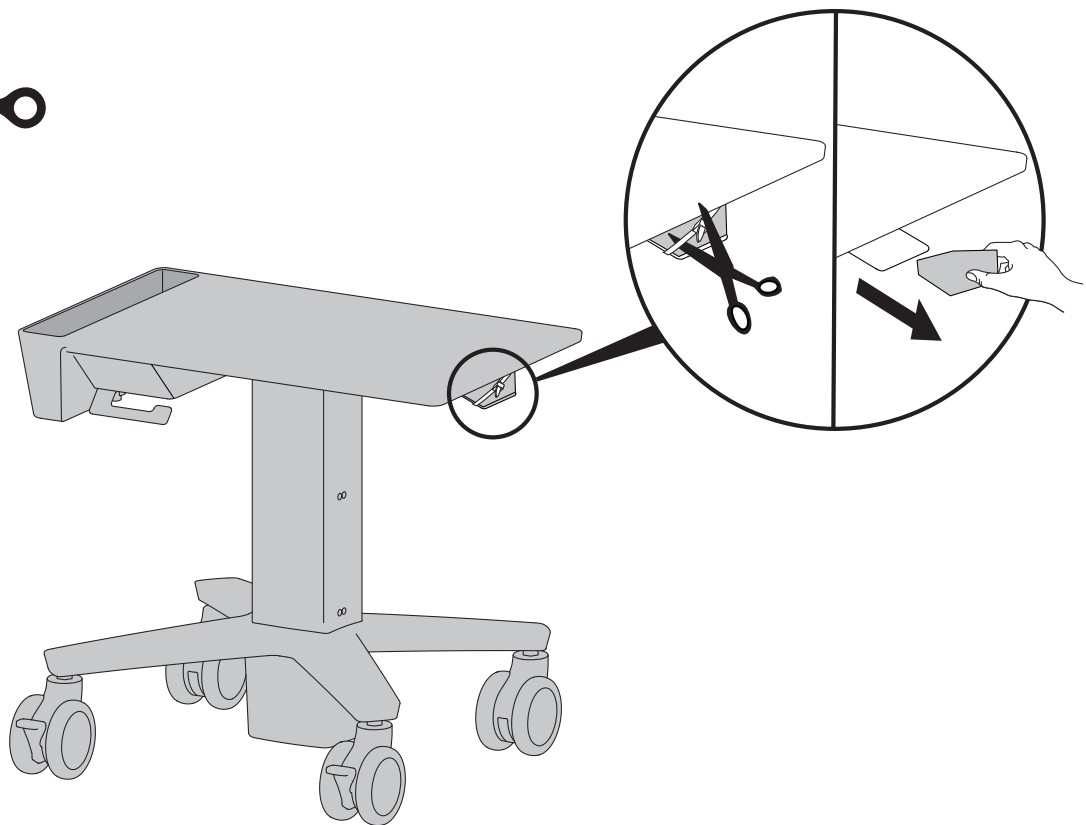

2

Zet de rem los om de staander te verplaatsen.
Rilasciare il freno per sollevare o abbassare il sostegno.
Lossa på bromsen för att flytta risern.

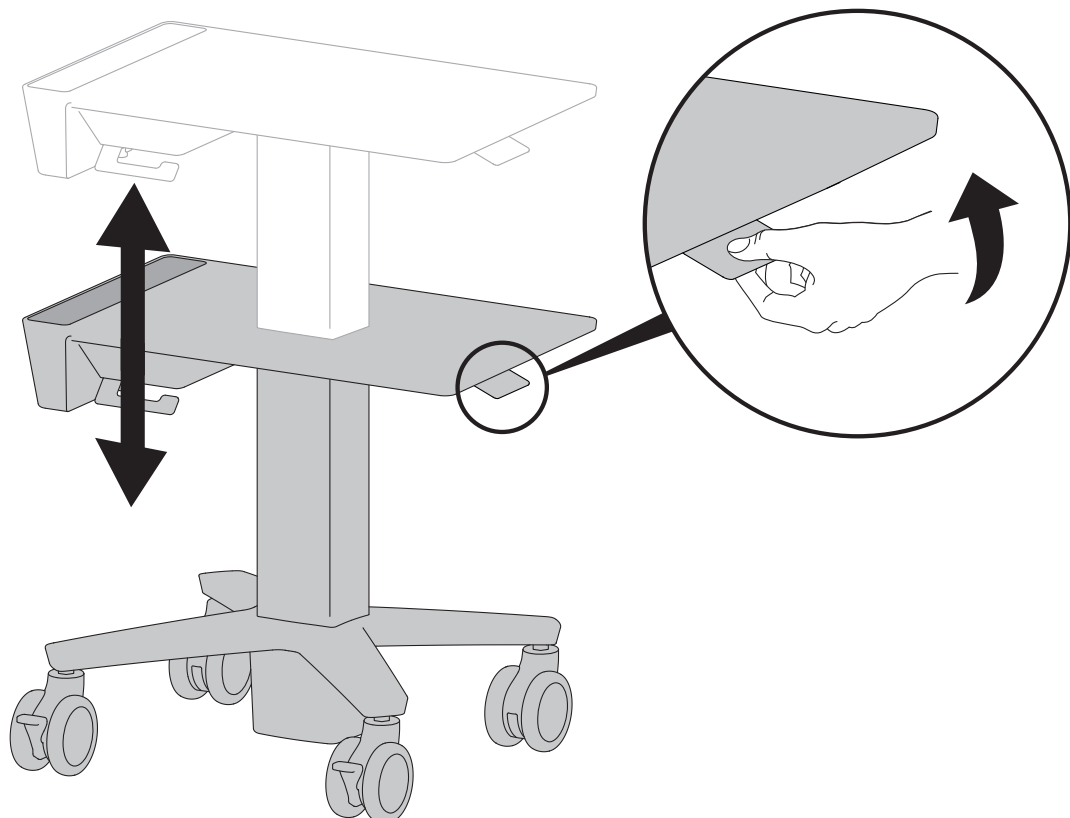

3



4mm
5 sided security wrench

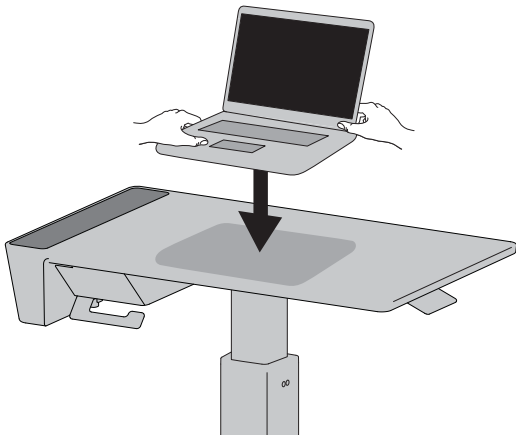

a

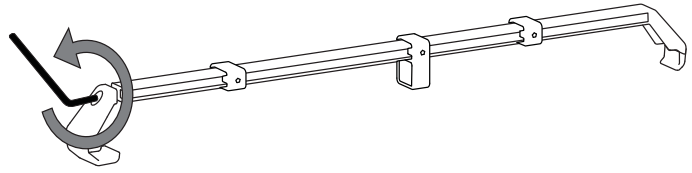

b

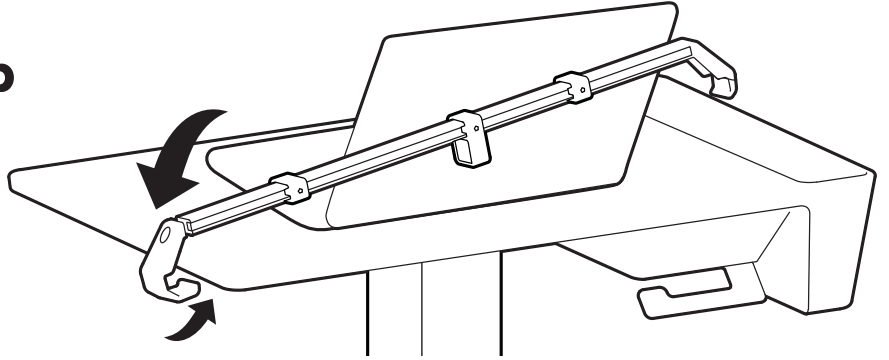

c

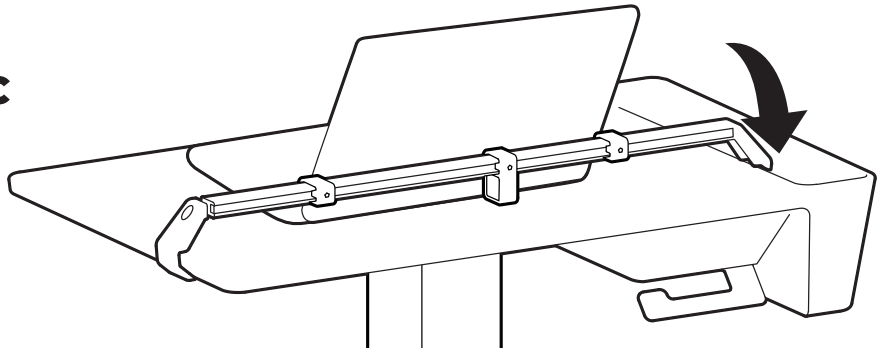

d

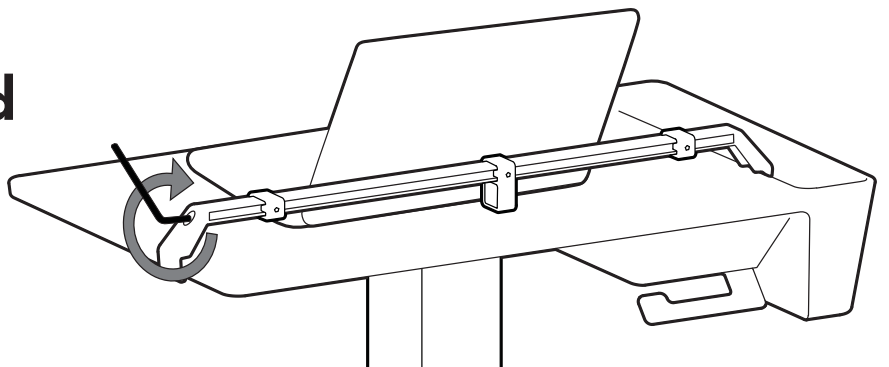

e

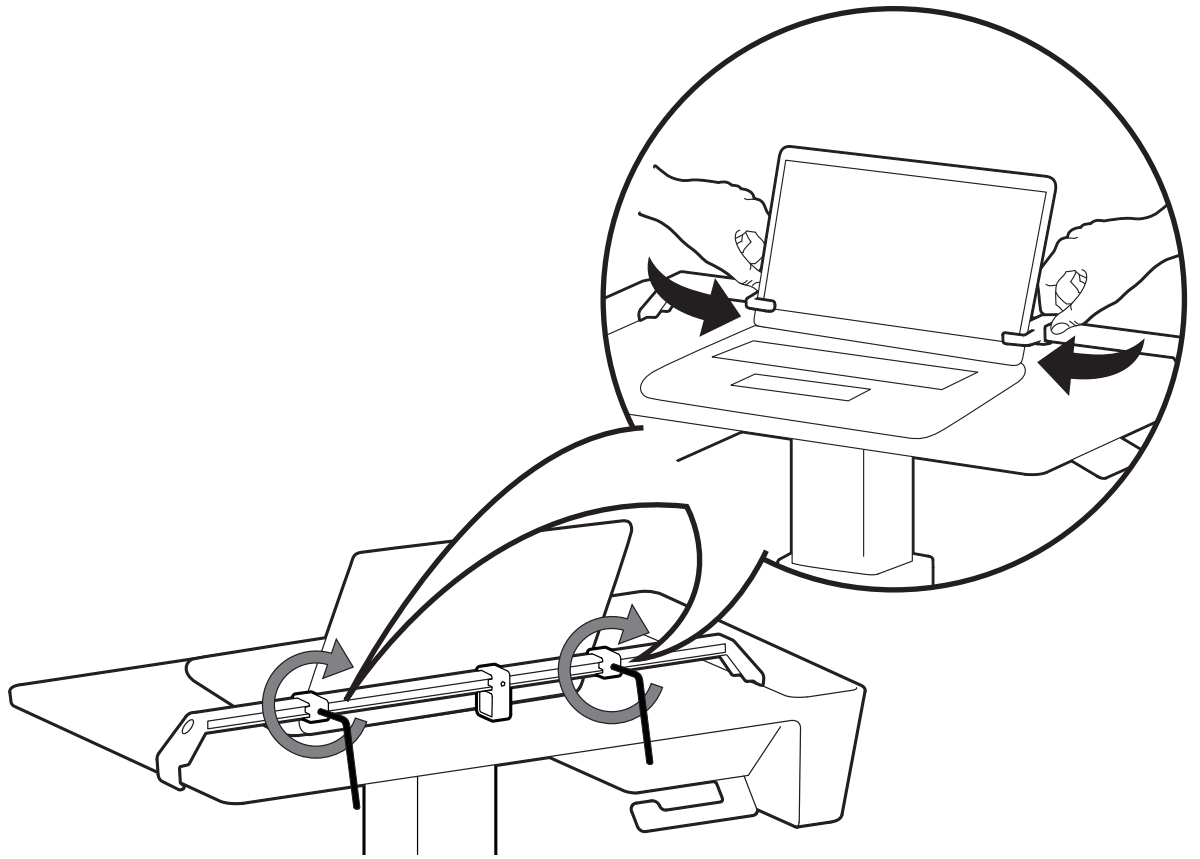

f

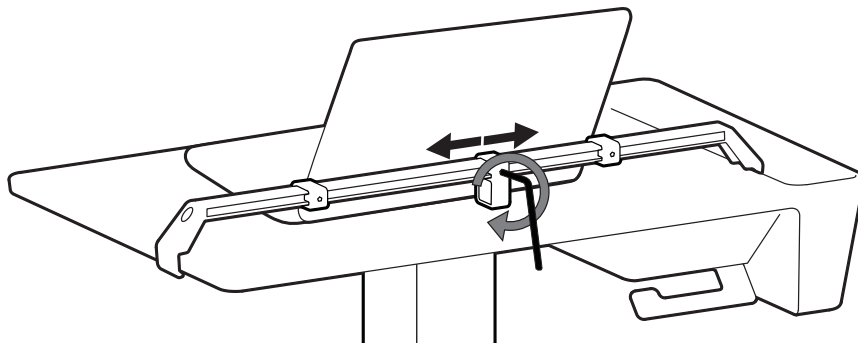

g

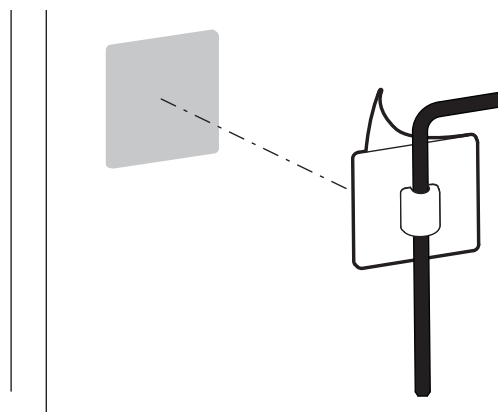

4

- LET OP: Laat voldoende speling in de kabel om volledige bewegingsbereik mogelijk te maken.
- ⚠ Voorzichtig: Om te voorkomen dat de snoeren mogelijk beklemd raken, dient u de instructies voor het leiden van de snoeren in dit handboek te volgen. Nalaten deze instructies te volgen kan de apparatuur beschadigen of persoonlijk letsel veroorzaken.
- NOTA: Lasciare sufficiente gioco per consentire al cavo l'intero intervallo di movimento.
- ⚠ Attenzione: Per evitare la possibilità di schiacciare i cavi, è importante seguire le istruzioni di instradamento dei cavi riportate nel presente manuale. La mancata osservanza delle presenti istruzioni può causare danni alle cose o infortuni personali.
- OBS! Lämna tillräckligt med spelrum för att tillåta ett komplett rörelseomfång för kabeln.
- ⚠ Var aktsam: För att undvika att kablarna kläms är det viktigt att följa kabeldragningsanvisningarna i denna handbok. Försummelse att följa dessa anvisningar kan leda till skador på utrustningen eller personskador.

a

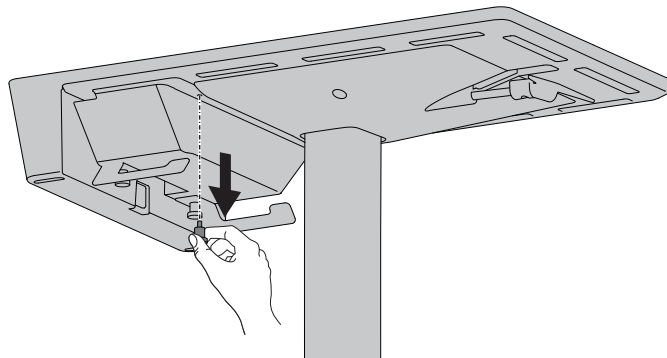

b

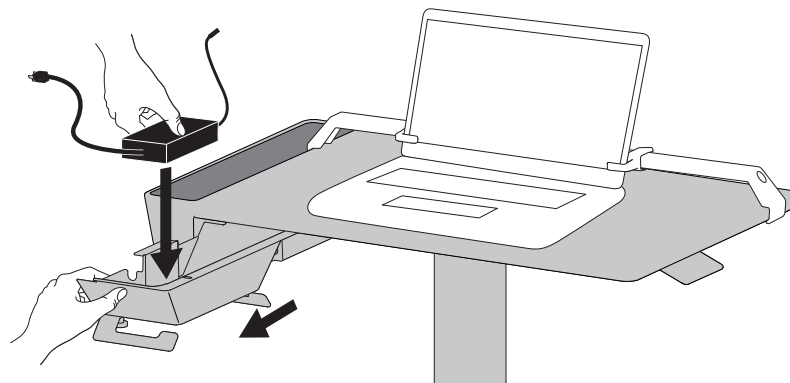

c

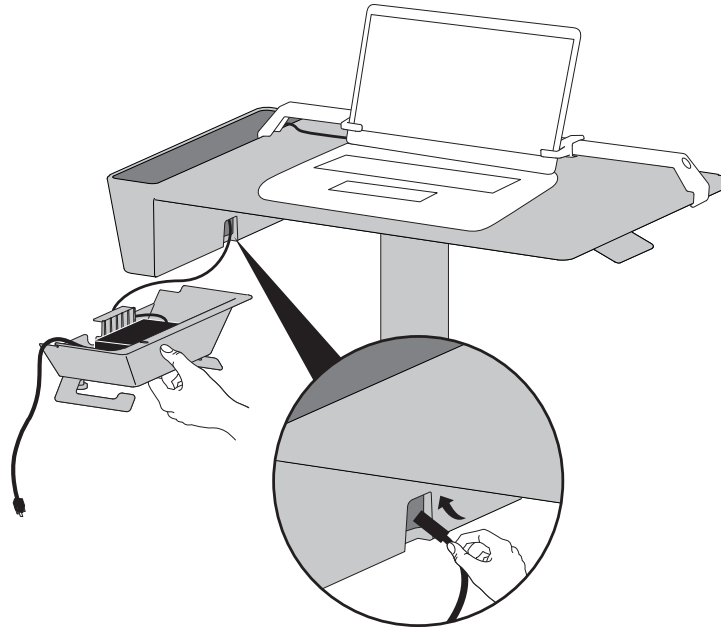

d

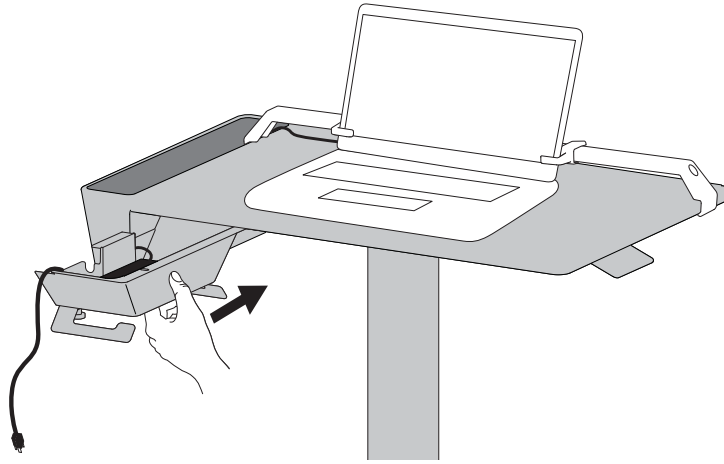

e

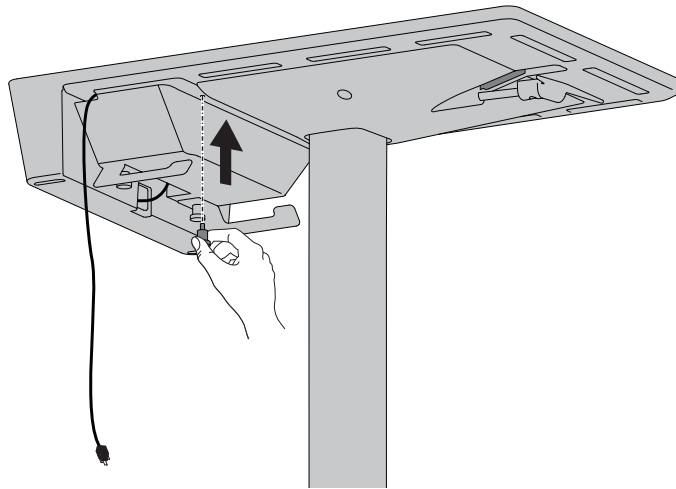

f

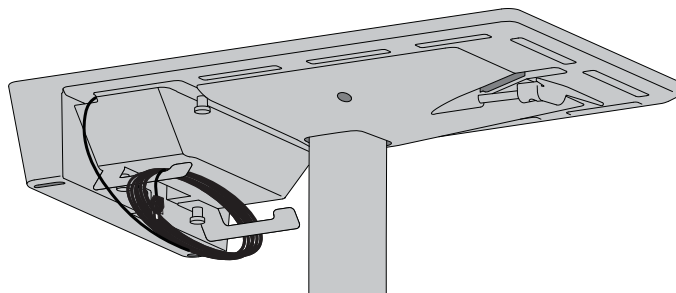

5 Zwenkwiel met 3 functies

Rotella orientabile a 3 funzioni
3-funktionshjul

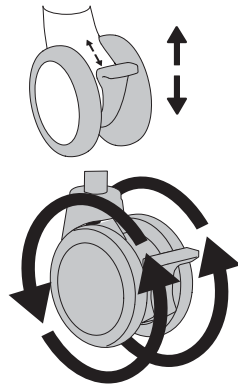
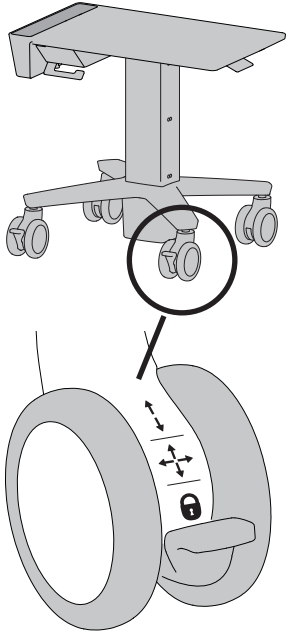

Wielrotatie
Rotazione rotella
Hjulrotation

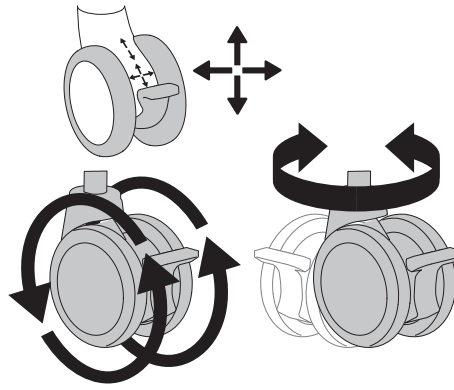

Wielrotatie en -zwenking
Rotazione rotella e perno
Hjulrotation och svängtapp

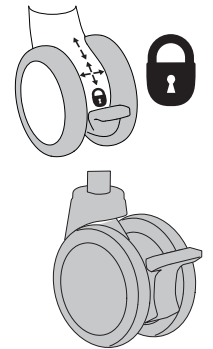

Vergrendeld
Bloccato
Låst



5 sided security wrench

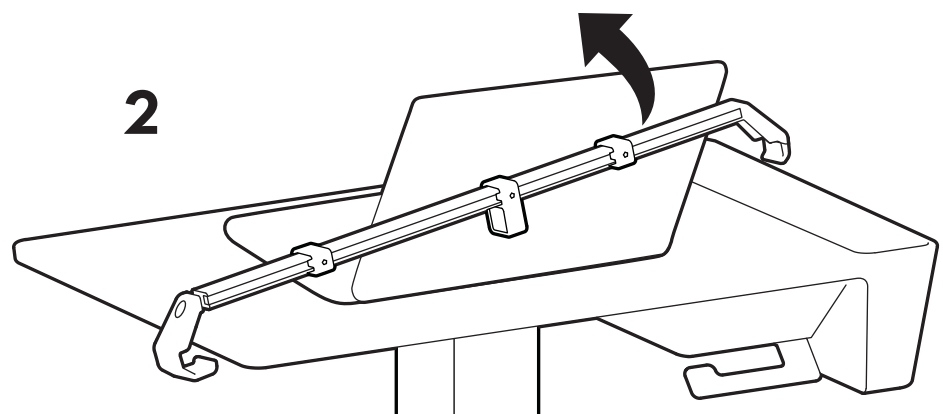
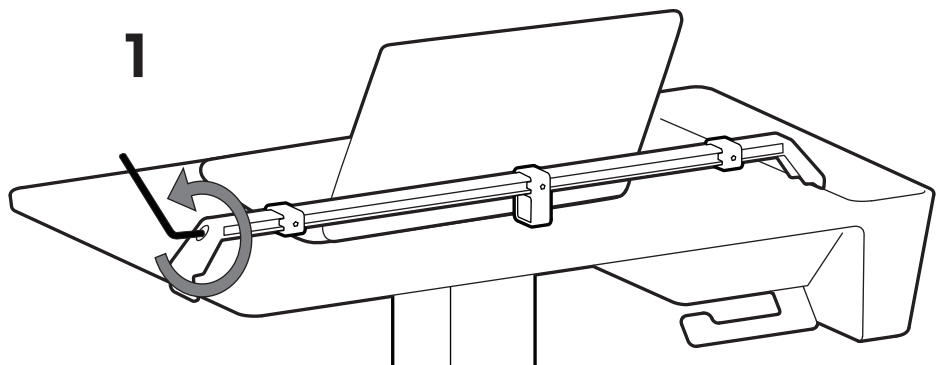

NL De nieuwste Gids voor installatie door de gebruiker kunt u vinden op: www.ergotron.com

Ga voor garantie naar: www.ergotron.com/warranty

Ga voor service naar: www.ergotron.com

Plaatselijke telefoonnummers voor de klantendienst kunt u vinden op: <http://contact.ergotron.com>

IT Per la versione più recente della Guida all'installazione per l'utente, visitare il sito web: www.ergotron.com

Per la garanzia visitare: www.ergotron.com/warranty

Per assistenza visitare: www.ergotron.com

Per conoscere i numeri di telefono dell'assistenza clienti locale, visitare: <http://contact.ergotron.com>

SV För den senaste Installationshandboken se: www.ergotron.com

För garanti, gå till: www.ergotron.com/warranty

För service, gå till: www.ergotron.com

För lokala kundtjänstnummer, gå till: <http://contact.ergotron.com>

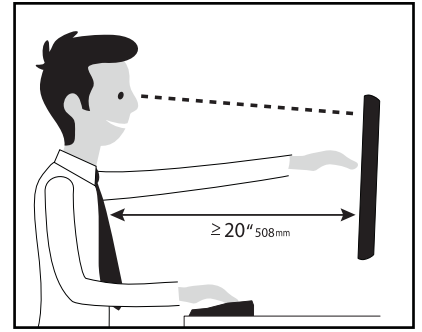

Learn more about ergonomic computer use at:
www.ergotron.com/ergonomics

NL LET OP: Als u contact opneemt met de klantenservice, geef dan het serienummer door.

IT NOTA: In occasione di contatti con l'assistenza clienti, indicare il numero di serie.

SV OBS! När du kontaktar kundtjänst, hänvisa till serienumret.

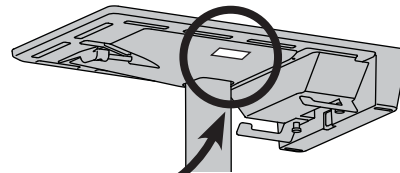

ergotron®

www.ergotron.com | USA: 1-800-888-8458 | Europe: +31 (0)33-45 45 600 | China: 400-120-3051 | Japan: japansupport@ergotron.com

© 2018 Ergotron, Inc. All rights reserved. CareFit™ and Constant Force™ are registered trademarks of Ergotron, Inc.

While Ergotron, Inc. makes every effort to provide accurate and complete information on the installation and use of its products, it will not be held liable for any editorial errors or omissions (including those made in the process of translation from English to another language), or for incidental, special or consequential damages of any nature resulting from furnishing this instruction and performance of equipment in connection with this instruction. Ergotron, Inc. reserves the right to make changes in the product design and/or product documentation without notification to its users. For the most current product information, or to know if this document is available in languages other than those herein, please contact Ergotron. No part of this publication may be reproduced, stored in a retrieval system, or transmitted in any form or by any means, electronic, mechanical, photocopying, recording or otherwise without the prior written consent of Ergotron, Inc., 1181 Trapp Road, Eagan, Minnesota, 55121, USA Patents Pending and Patented U.S. & Foreign. Ergotron is a registered trademark of Ergotron, Inc.