

ergotron®

WorkFit™ SR Dual Monitor

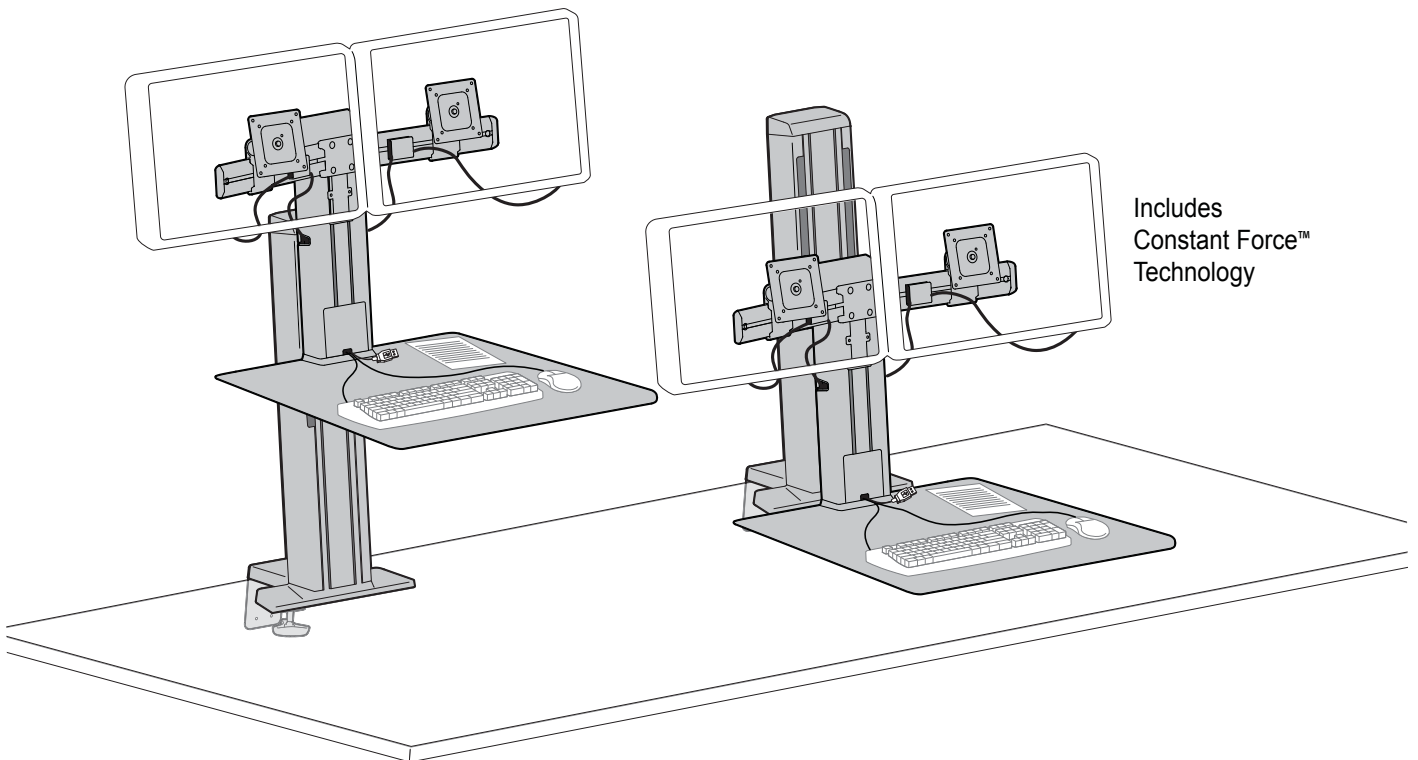

Do not throw away!
Cardboard blocks needed for
installation.

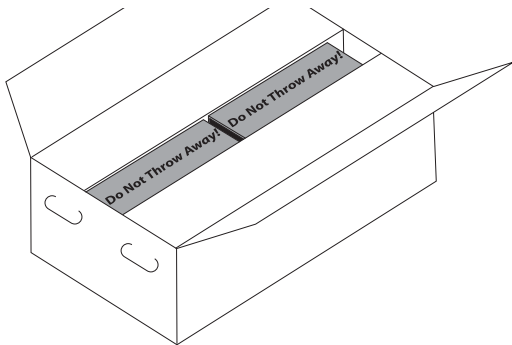

**NOTE: 10 feet of cable needed for proper
installation. Extra cables can be found at
www.ergotron.com**

Visit <http://www.ergotron.com/workfit-sr-install> for installation
instructional video.

English







For the latest User Installation Guide please visit: www.ergotron.com

English, Español, Français, Deutsch, Nederlands, Italiano, Svenska, 日本語, 汉语

www.ergotron.com | USA: 1-800-888-8458 | Europe: +31 (0)33-45 45 600 | China: 400-120-3051 | Japan: japansupport@ergotron.com

Hazard Symbols Review

These symbols alert users of a safety condition that demands attention. All users should be able to recognize and understand the significance of the following Safety Hazards if encountered on the product or within the documentation. Children who are not able to recognize and respond appropriately to Safety Alerts should not use this product without adult supervision!

Symbol	Signal Word	Level of Hazard
	NOTE	A NOTE indicates important information that helps you make better use of this product.
	CAUTION	A CAUTION indicates either potential damage to hardware or loss of data and tells you how to avoid the problem.
	WARNING	A WARNING indicates either potential for property damage, personal injury, or death.
	ELECTRICAL	An Electrical indicates an impending electrical hazard which, if not avoided, may result in personal injury, fire and/or death.

Safety



Important! You will need to adjust this product after installation is complete. Make sure all your equipment is properly installed on the product before attempting adjustments. This product should move smoothly and easily through the full range of motion and stay where you set it. If movements are too easy or difficult or if product does not stay in desired positions, follow the adjustment instructions to create smooth and easy movements. Depending on your product and the adjustment, it may take many turns to notice a difference. Any time equipment is added or removed from this product, resulting in a change in the weight of the mounted load, you should repeat these adjustment steps to ensure safe and optimum operation.

 **Warning:** Because mounting surface materials can vary widely, it is imperative that you make sure mounting surface is strong enough to handle mounted product and equipment.

 **Warning:** Follow the instructions in this manual to securely clamp this product to your mounting surface. Failure to do so may result in equipment damage or personal injury.

 **Warning:** To avoid the potential to pinch cables it is important to follow the cable routing instructions in this manual. Failure to follow these instructions may result in equipment damage or personal injury.

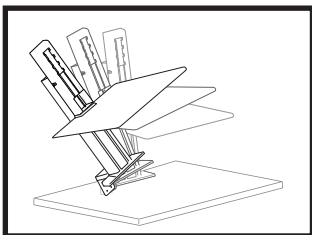

Warning: Tipping Hazard. Support the stand until the clamp is securely tightened. Failure to follow these instructions may result in the stand tipping over causing possible equipment damages and/or personal injury.

! WARNING

STORED ENERGY HAZARD!
DO NOT OPEN TOWER OR REMOVE SAFETY GUARD!

A primary mechanism within the tower is under tension and can be hazardous to people exposed to it under certain extreme conditions. DO NOT open the tower; DO NOT attempt to service the cart/stand. DO NOT remove safety guards or labels designed to protect or inform of possible hazards. Only Ergotron-approved installers may service or otherwise modify cart/stand. Failure to heed this Warning may result in serious Personal Injury and Damage both to the cart/stand and equipment.

822-959-00



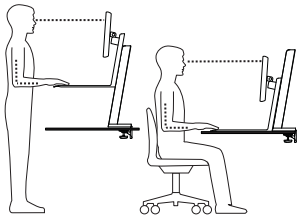

Features & Specifications

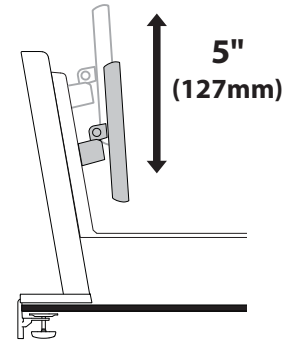
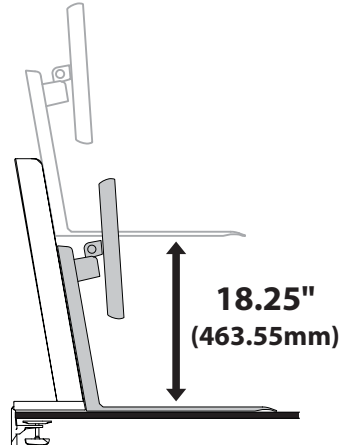
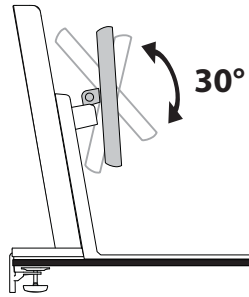
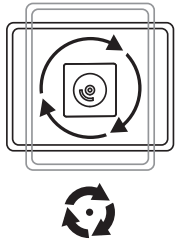

CAUTION: DO NOT EXCEED MAXIMUM LISTED WEIGHT CAPACITY. SERIOUS INJURY OR PROPERTY DAMAGE MAY OCCUR!

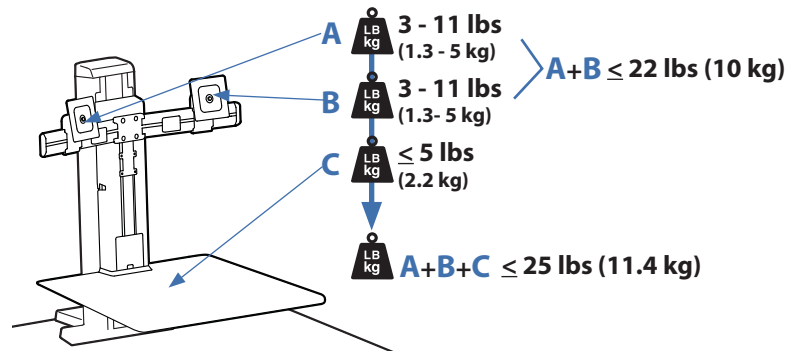

Components

	A	B		C	D
1	1x	1x	1x	2x	2x
2		1x	1x		M4 x 8mm
3			2x	2x	2x
4	1x		2x	8x	2x
5	1x		1x	4x	4x
6	2x	1x	8x 8x	4x	1x

Tools Needed



1 Lay engine down.

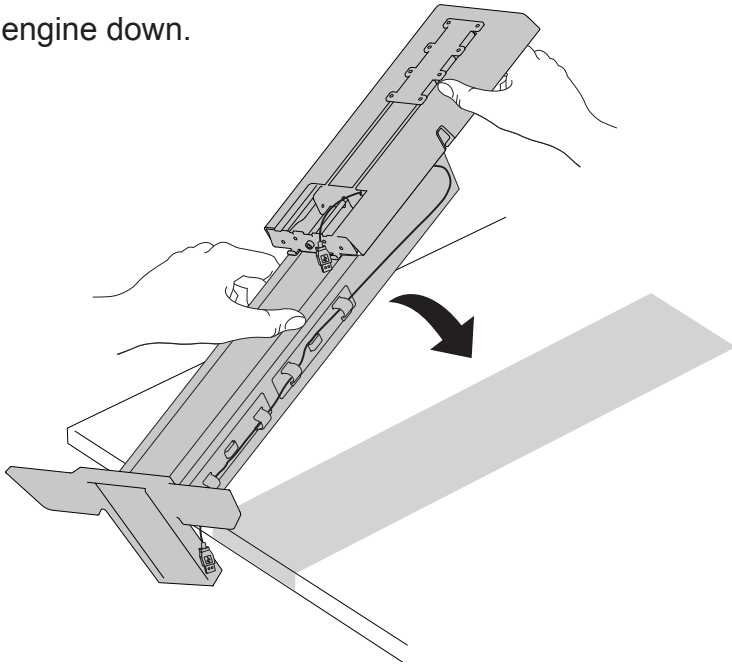

2 Attach worksurface to bottom of riser.

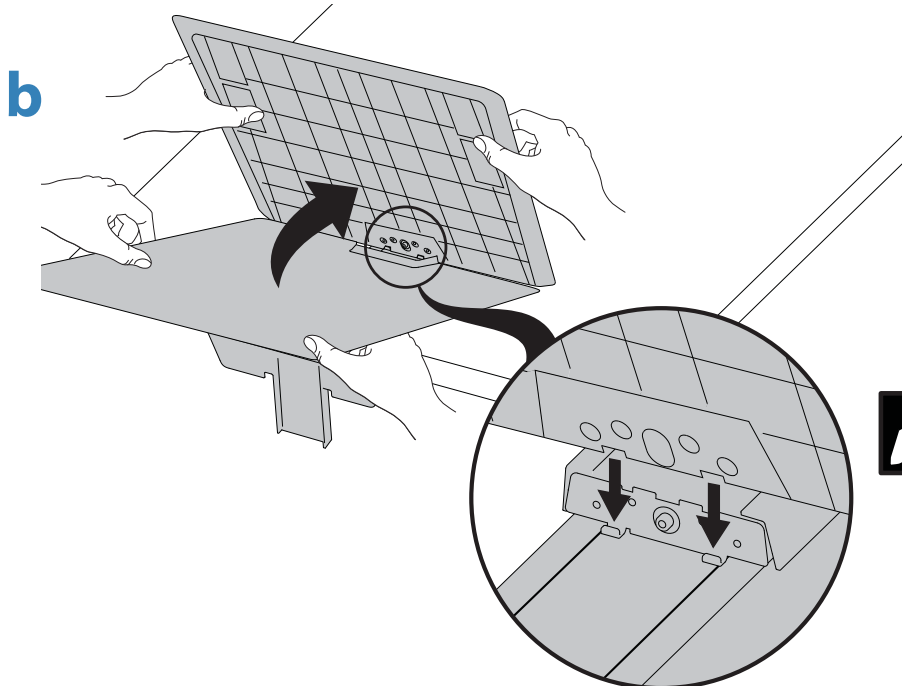
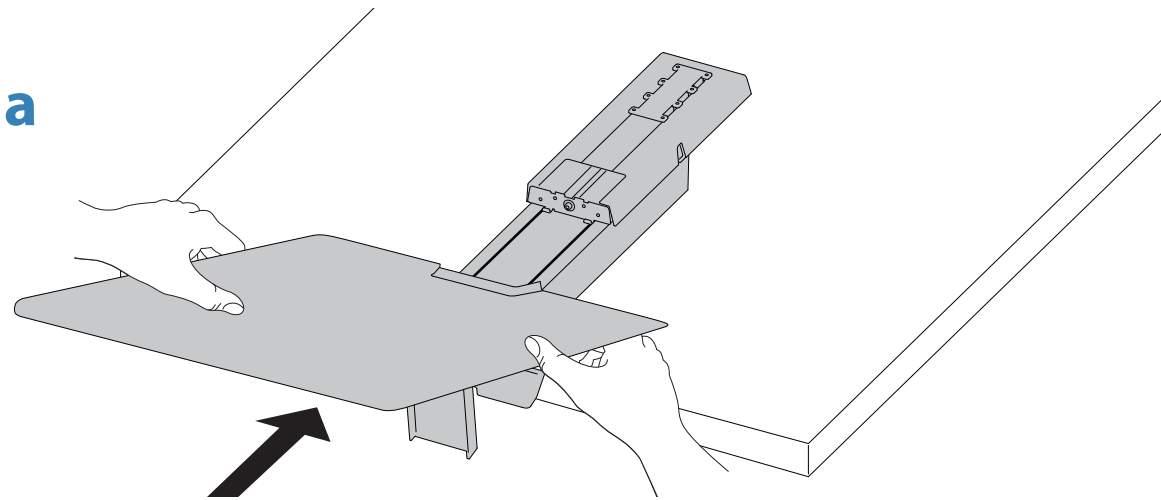

NOTE: Make sure slots align when installing work surface.

C Screw worksurface into riser.

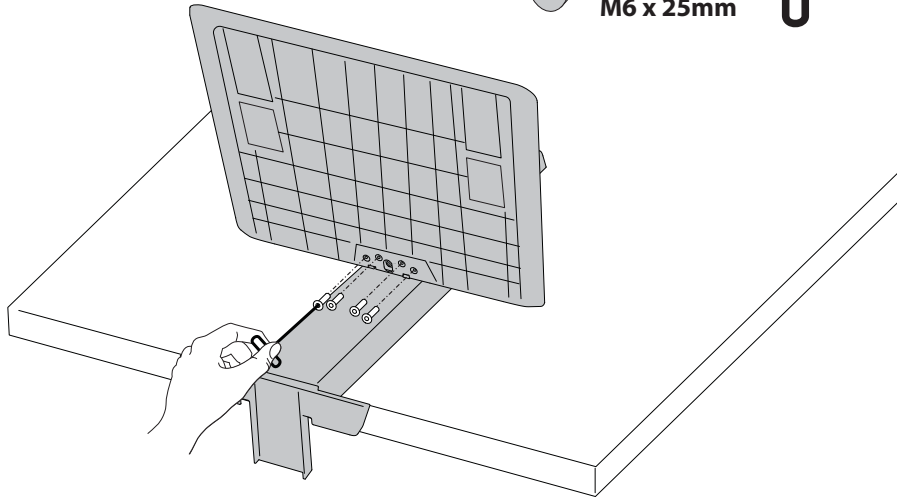
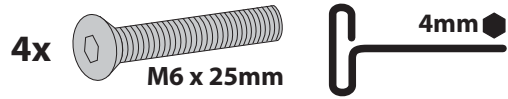

3 Disassemble desk clamp.

a Remove two screws from clamp base.

b Remove clamp from clamp base.

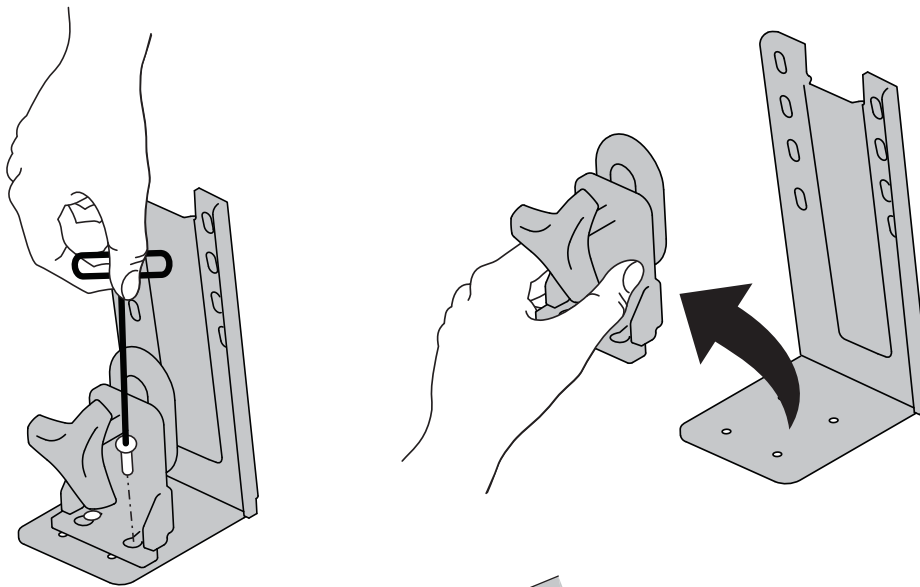

C Measure desk thickness.

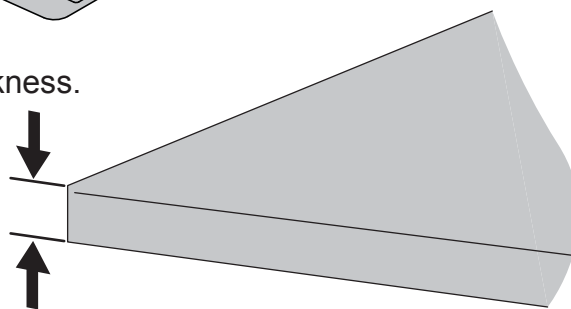
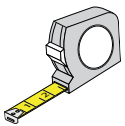

d Partially reinstall screws into clamp base. (1.5 revolutions)

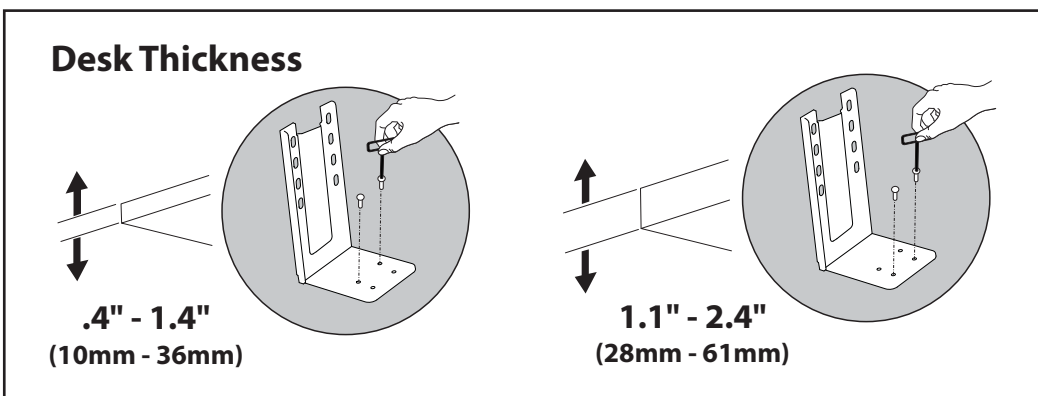

4 Secure clamp base to riser.

a Measure desk depth.

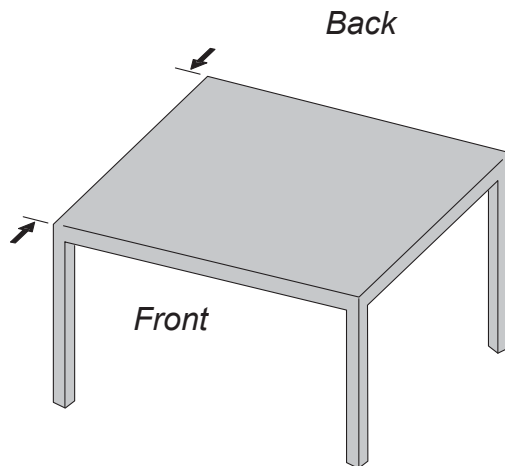
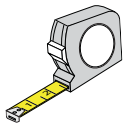

b Slide clamp base into bottom of riser.

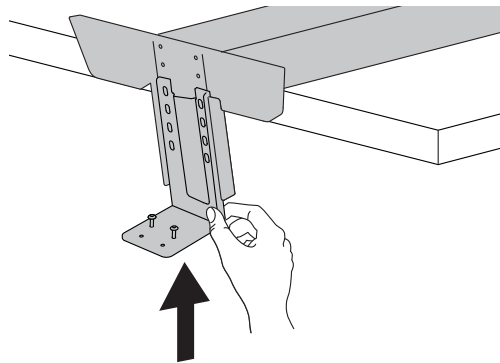

c Secure clamp base to riser.



4x M6 x 12mm



NOTE: Align the clamp window with the line on the bottom of the riser for your desk depth.

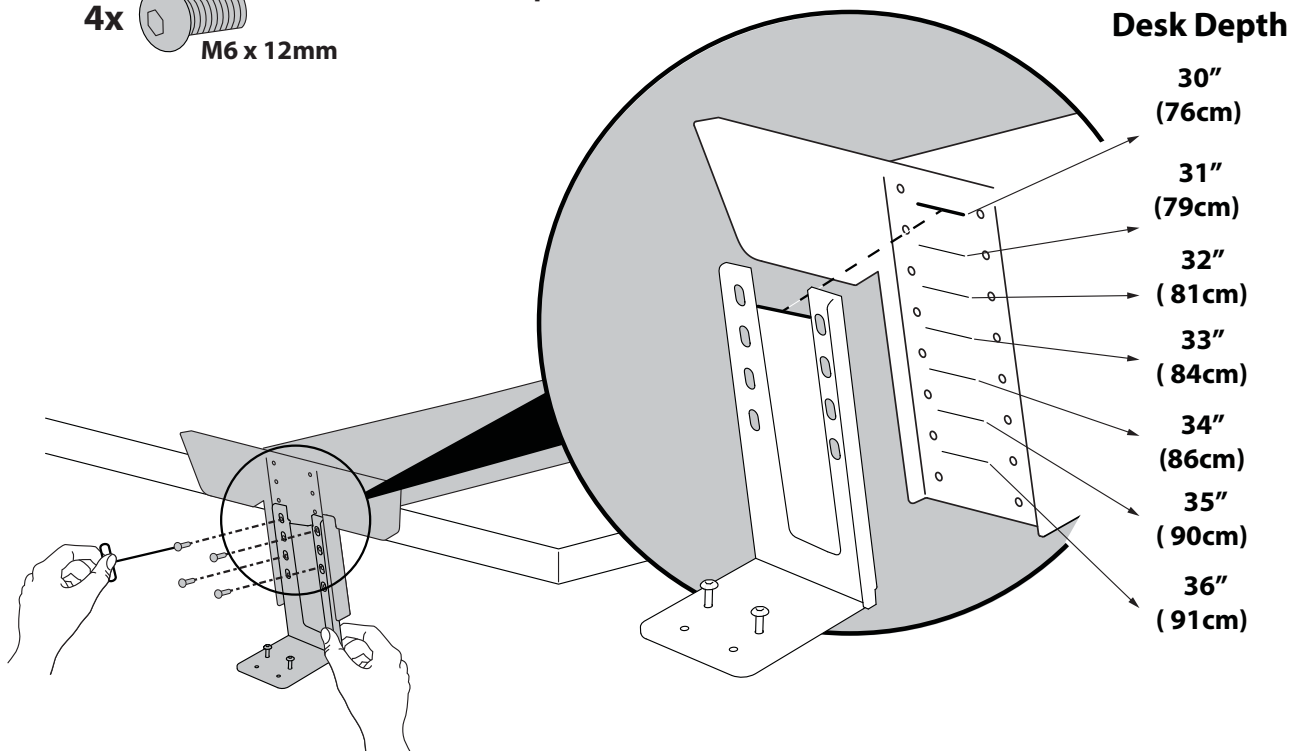
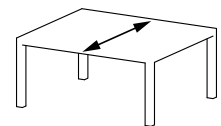

5 Mount to desk.

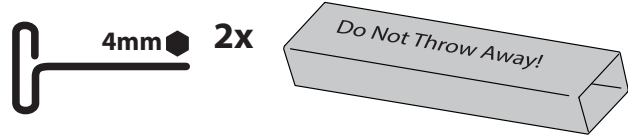

a Two person lift.

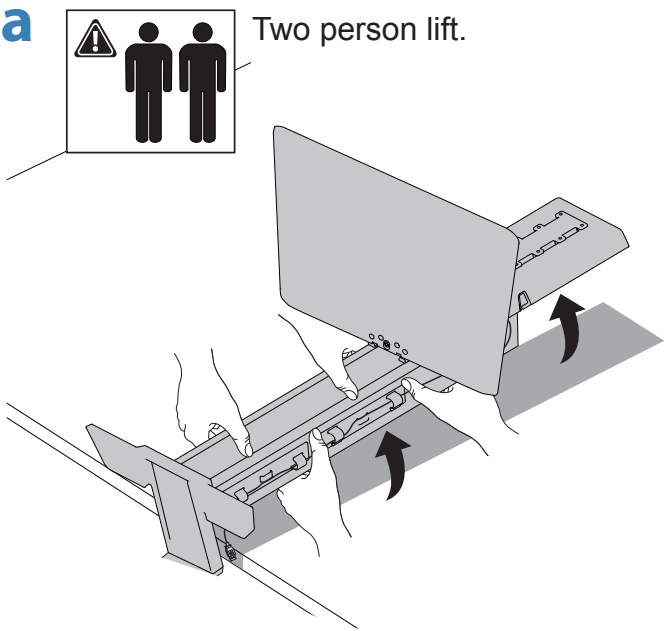

b

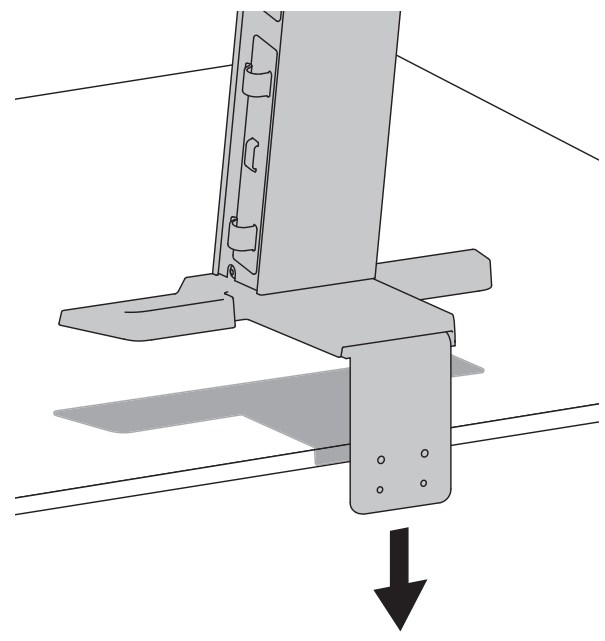

c Use cardboard blocks to support worksurface.

Caution:
Worksurface not stable until
clamp is secured.

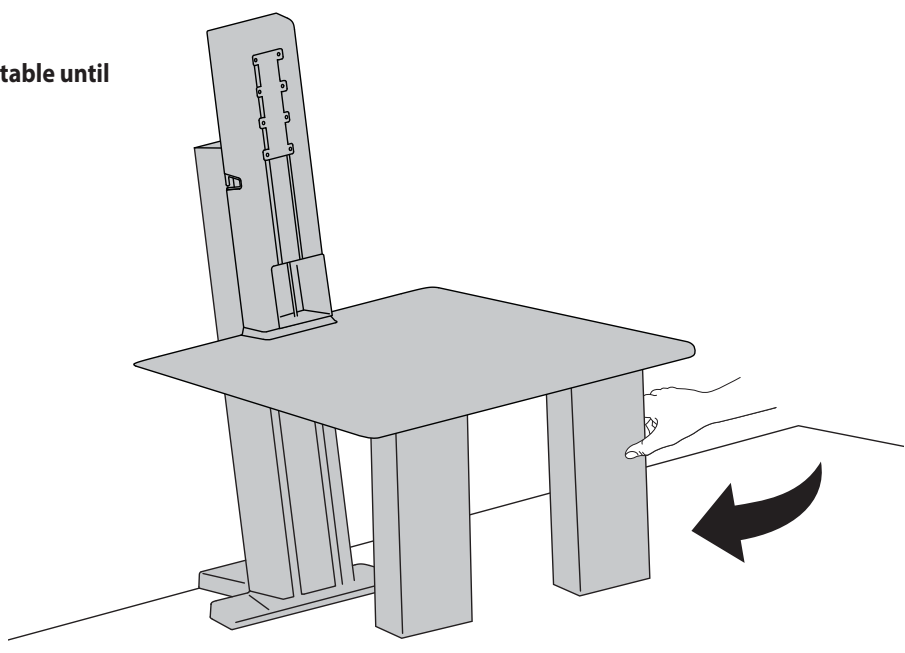

d Secure clamp to clamp base.

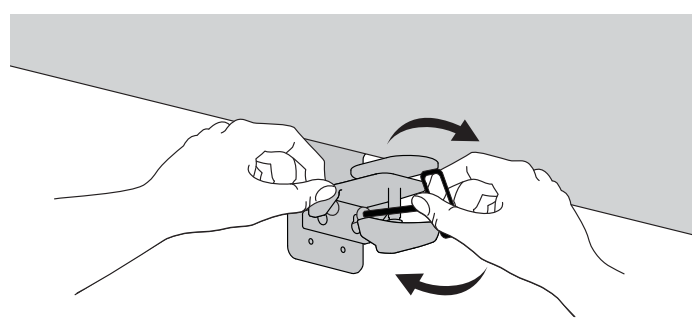
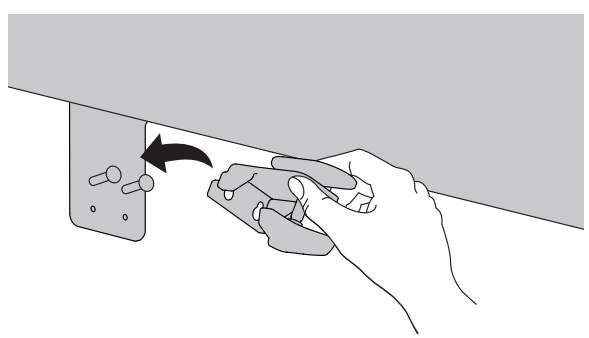

e Tighten clamp.



Caution: Follow the instructions in this manual to securely clamp this product to your mounting surface. Failure to do so may result in equipment damage or personal injury.

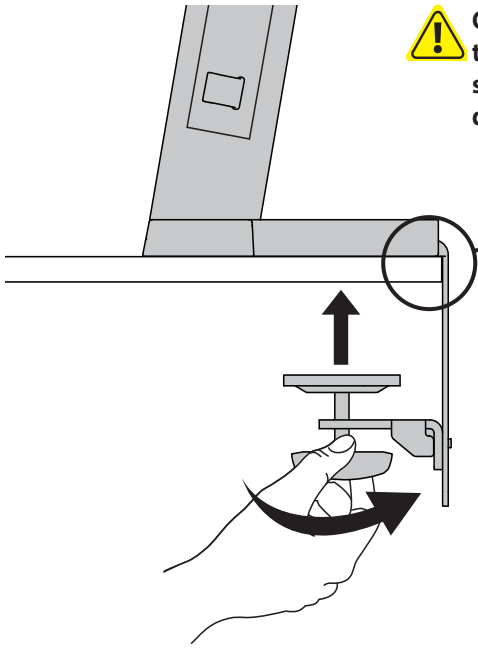

NOTE: Push clamp base to edge of mounting surface.

f

Remove cardboard blocks from underneath work surface

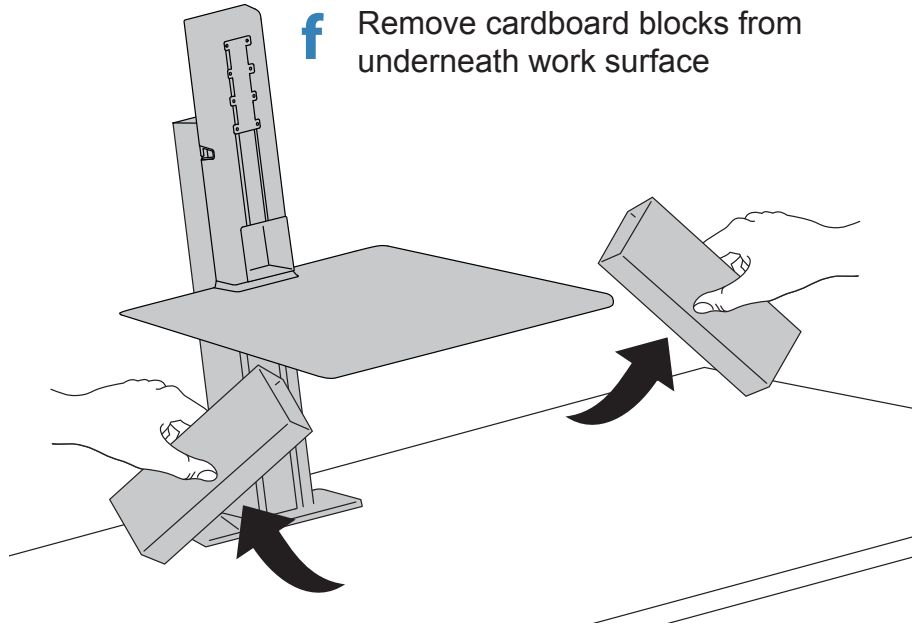

6 Screw crossbar to riser.



4mm

4x

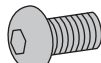

M6 x 10mm

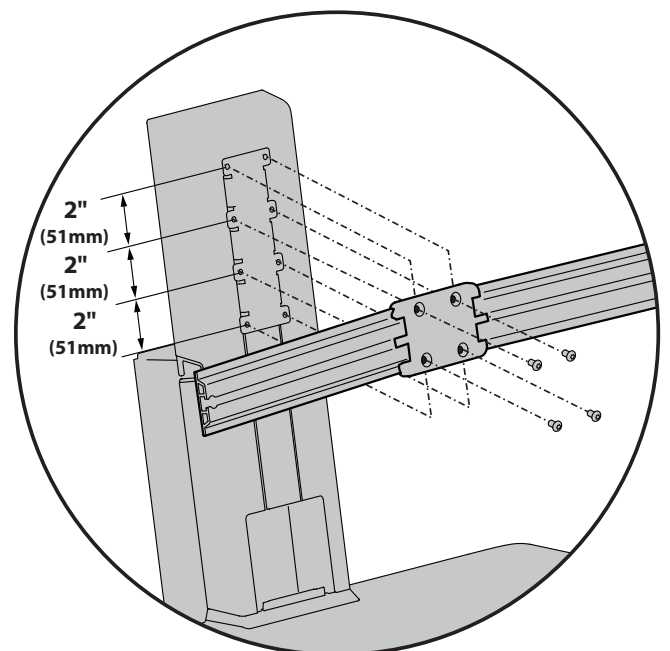
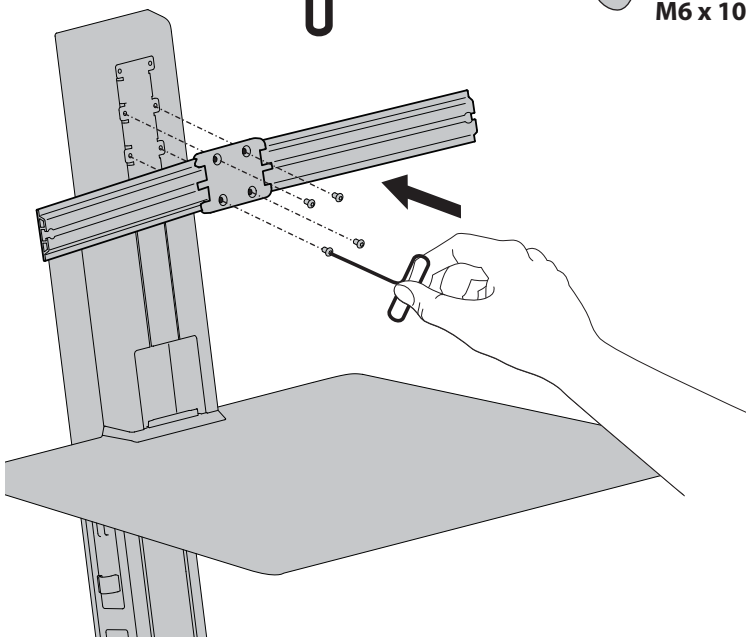

NOTE: Crossbar can be mounted to accommodate different heights.

7

Slide cable routing clips onto crossbar.

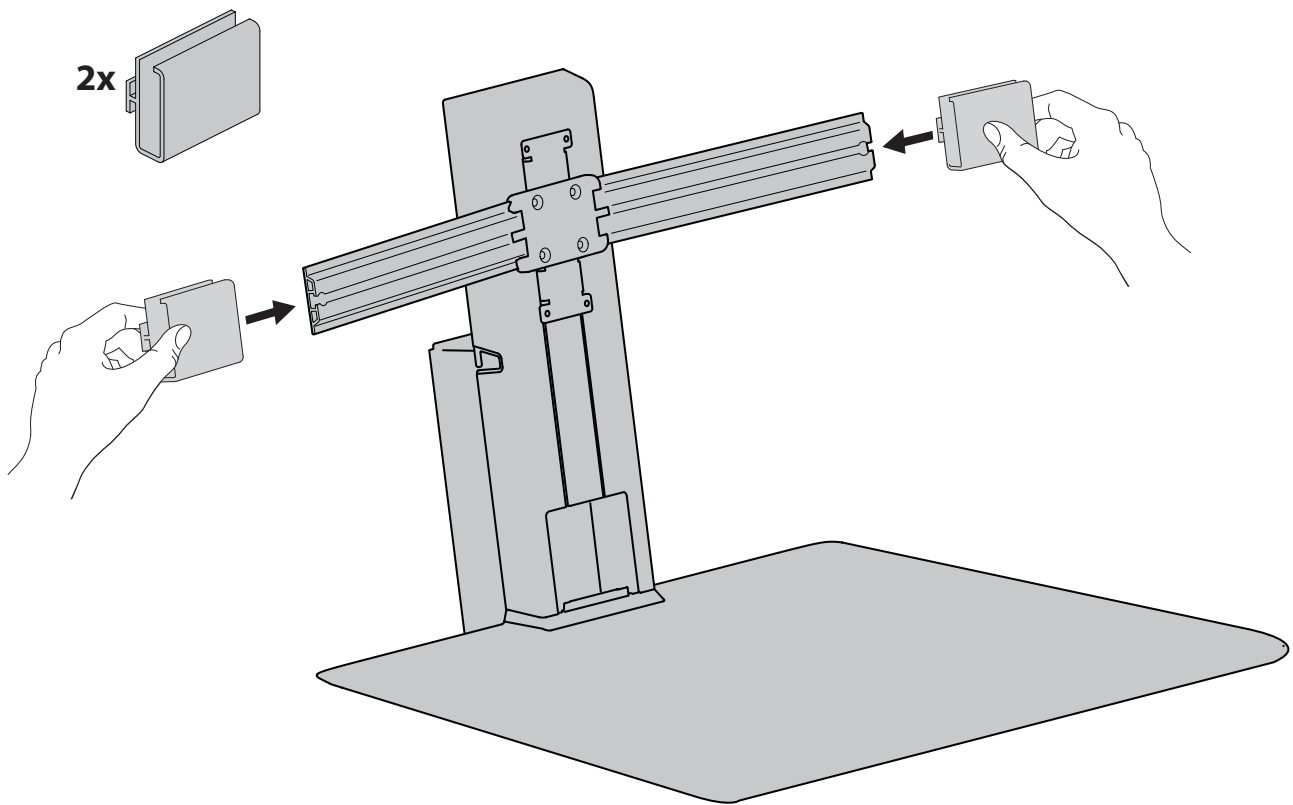

8

a Lay monitor facedown on worksurface.

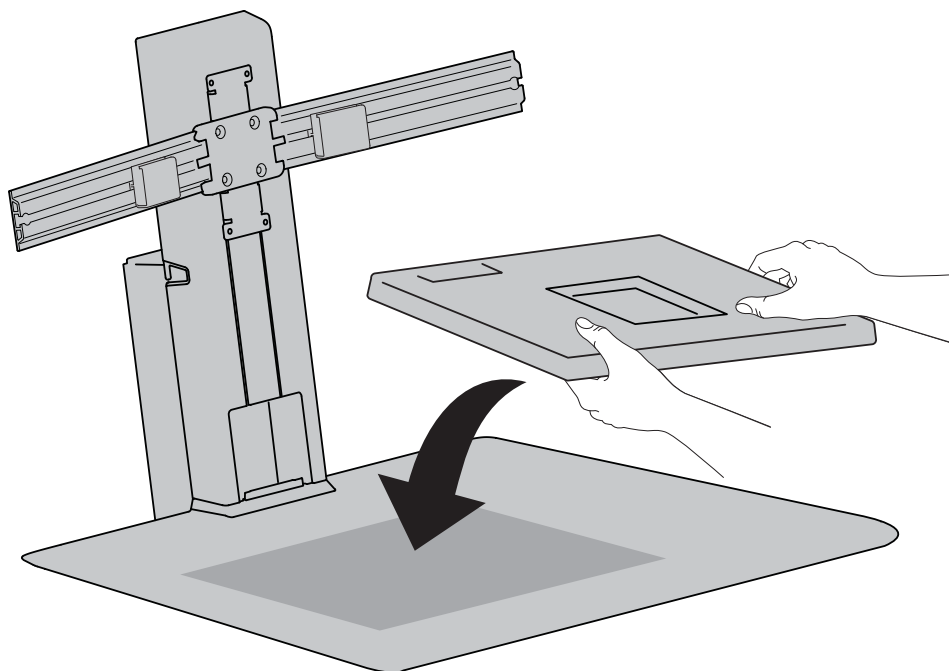

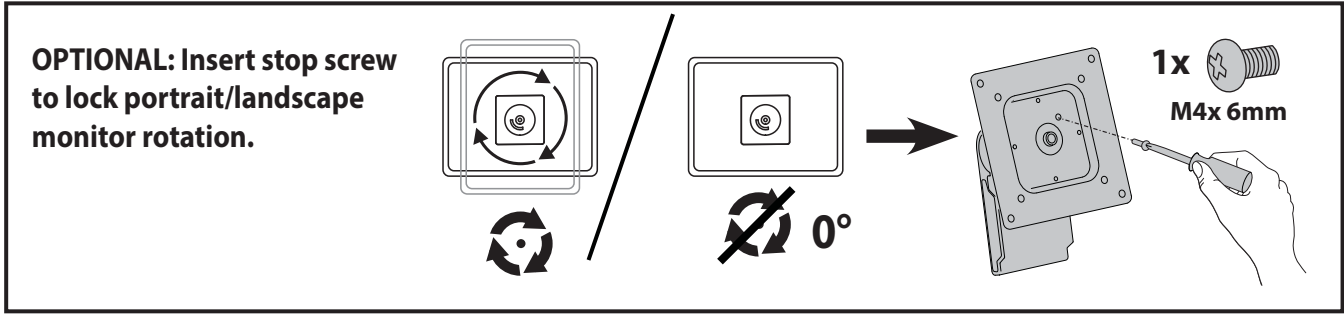

b Loosely thread thumb screws into mounting brackets.

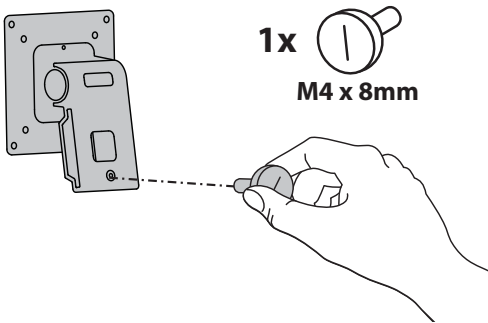

c Attach monitors to mounting brackets.

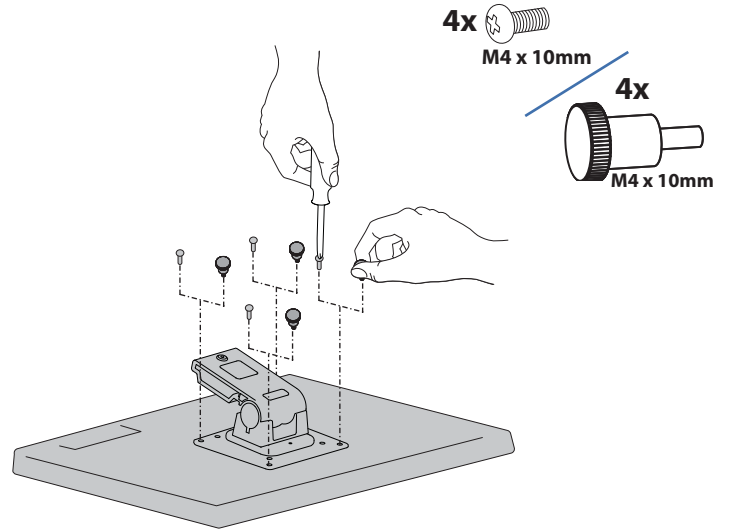

9 Cable Routing

a Plug power and video cables into monitor by routing through cable clip.

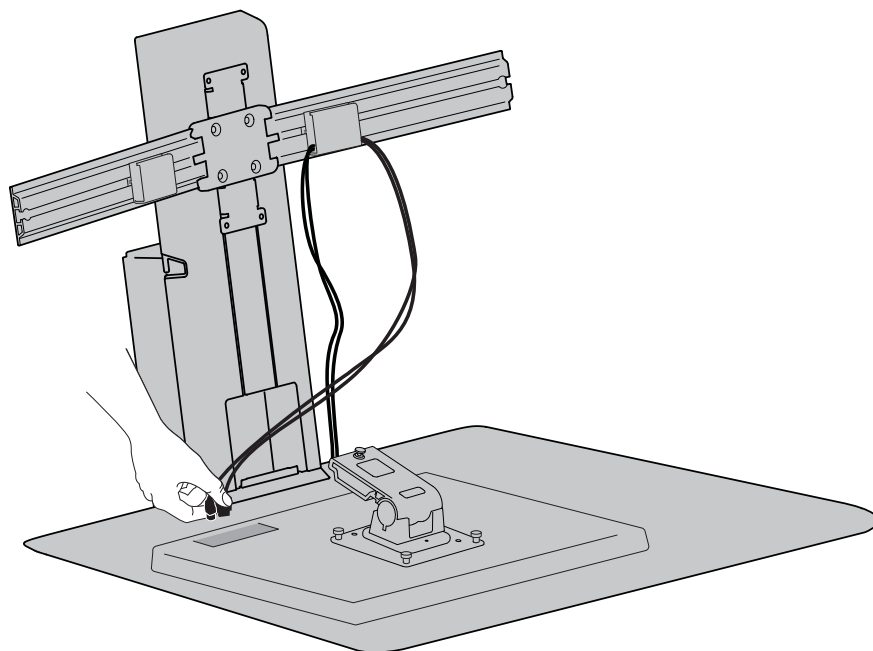

b Route cables through cable clips on side of riser.

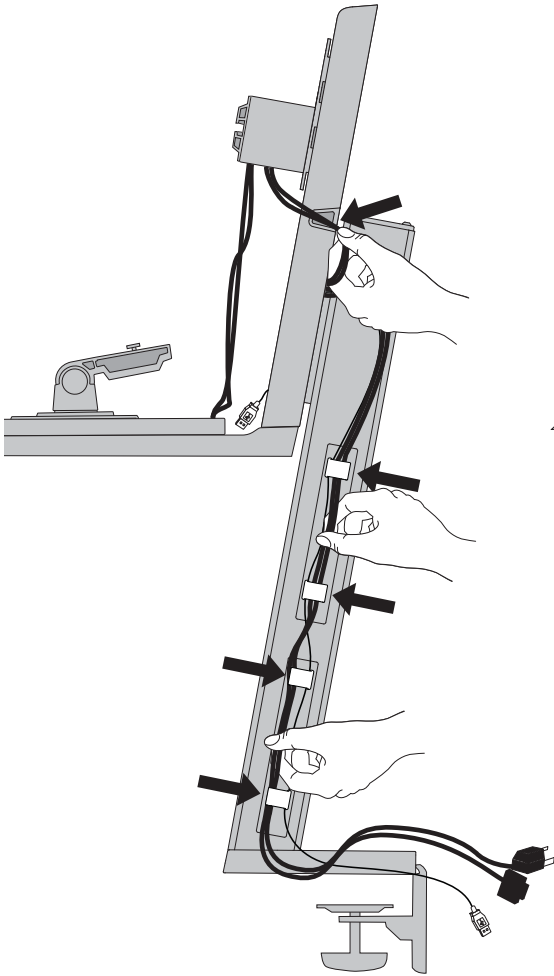

c Check cable lengths.

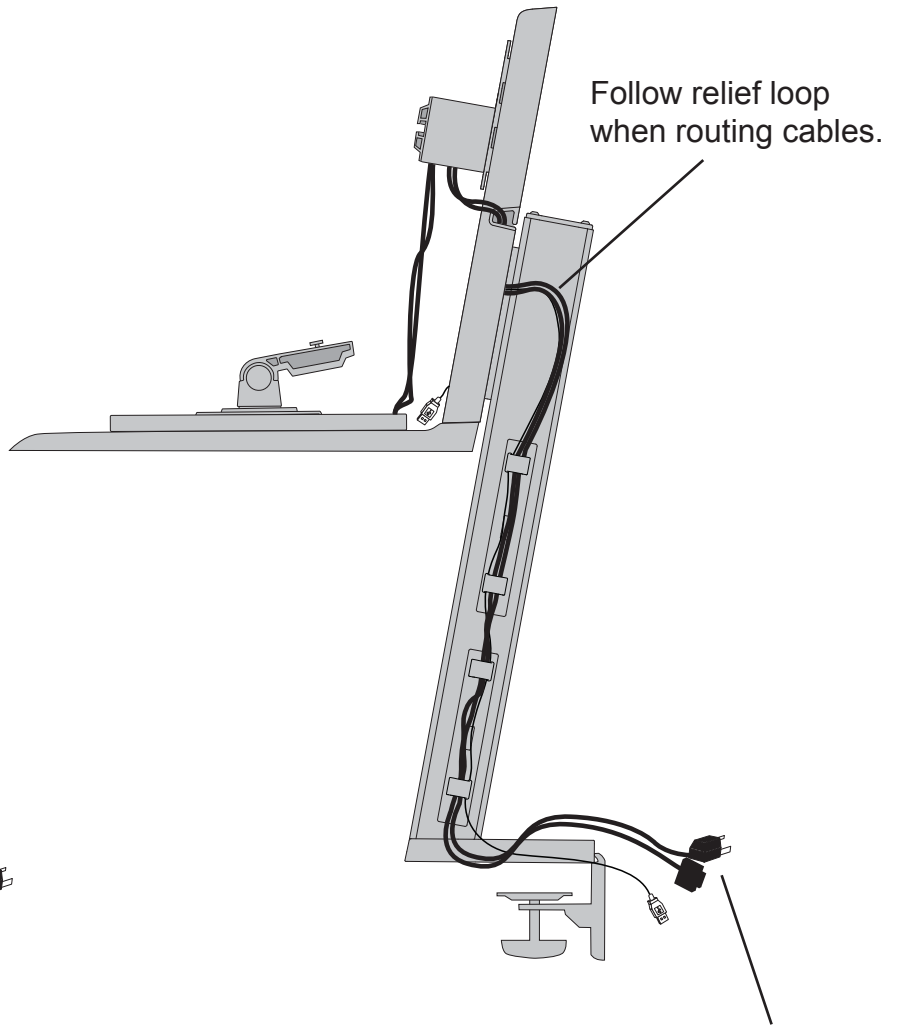

Make sure there is enough cable.
(10ft cable recommended)

10 Slide monitor onto crossbar.



NOTE: Monitor mounting brackets can be installed upside down to lower monitor 4".

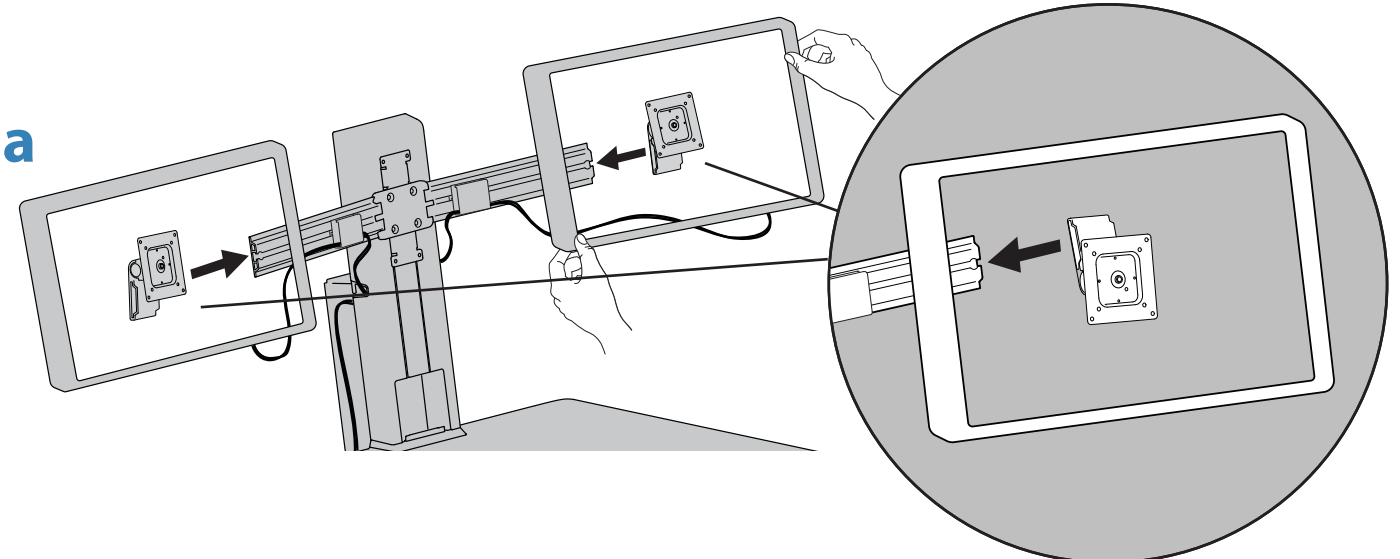

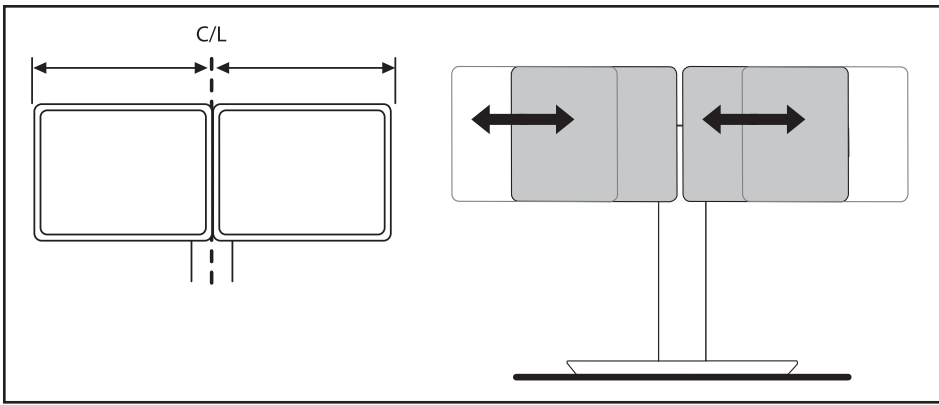



! Center total width of mounted equipment on stand.

b Tighten thumb screws to secure monitors.

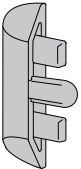

- 11** 2x  2x  M3 x 6mm 1x  2mm

a Attach end caps to crossbar.

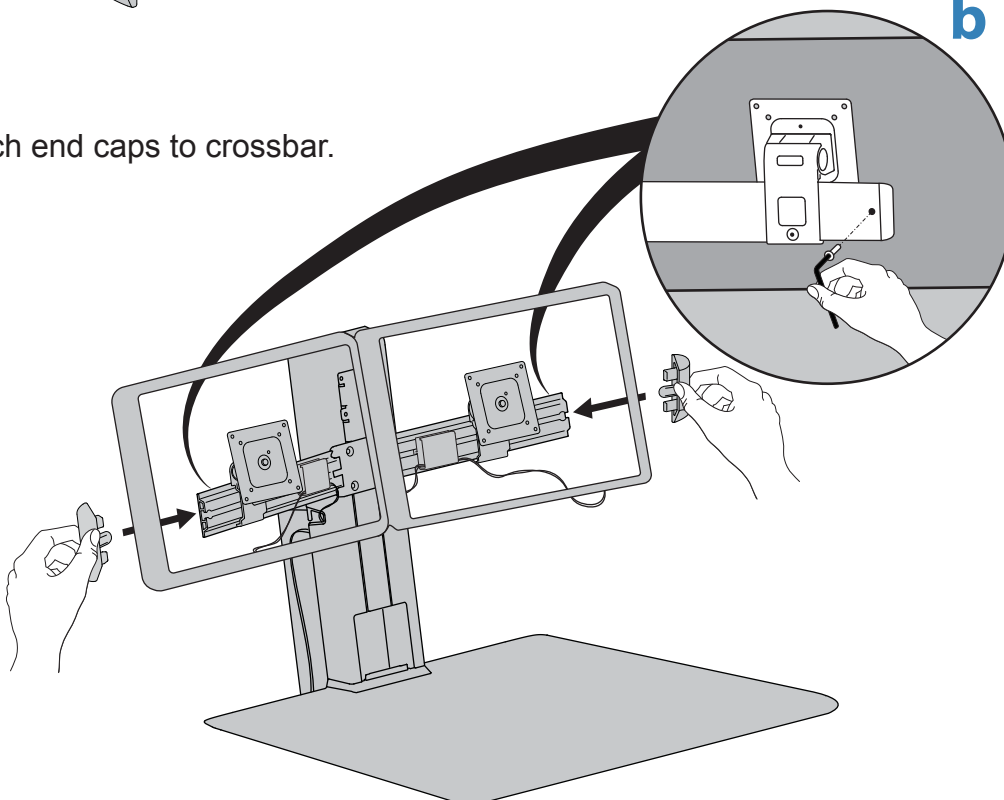

b Secure end caps to crossbar.

12 Keyboard and Mouse cables

a

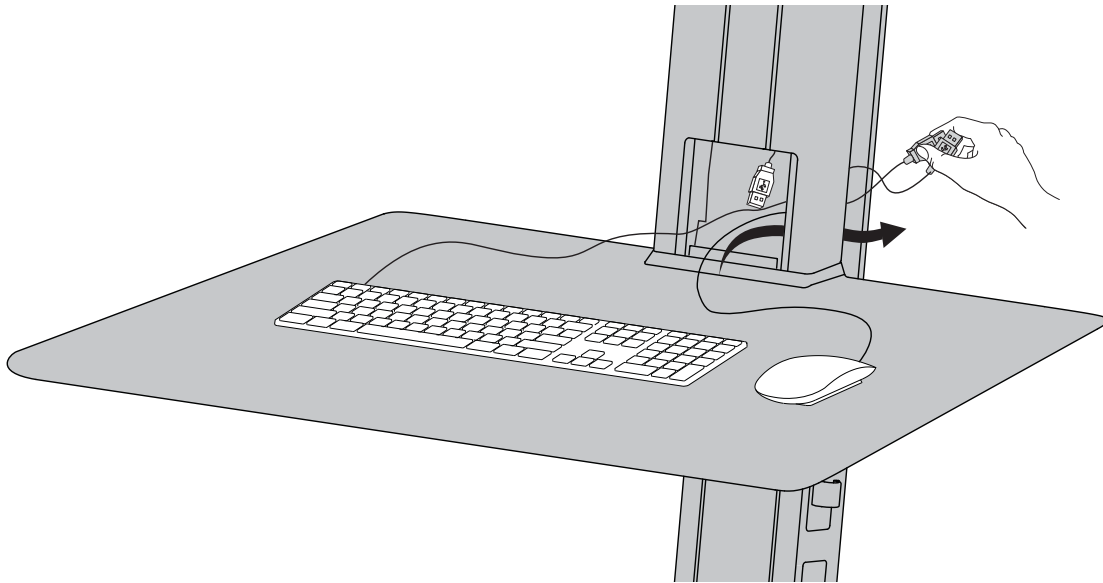

b Route mouse and keyboard cables through cable clips on side of riser.

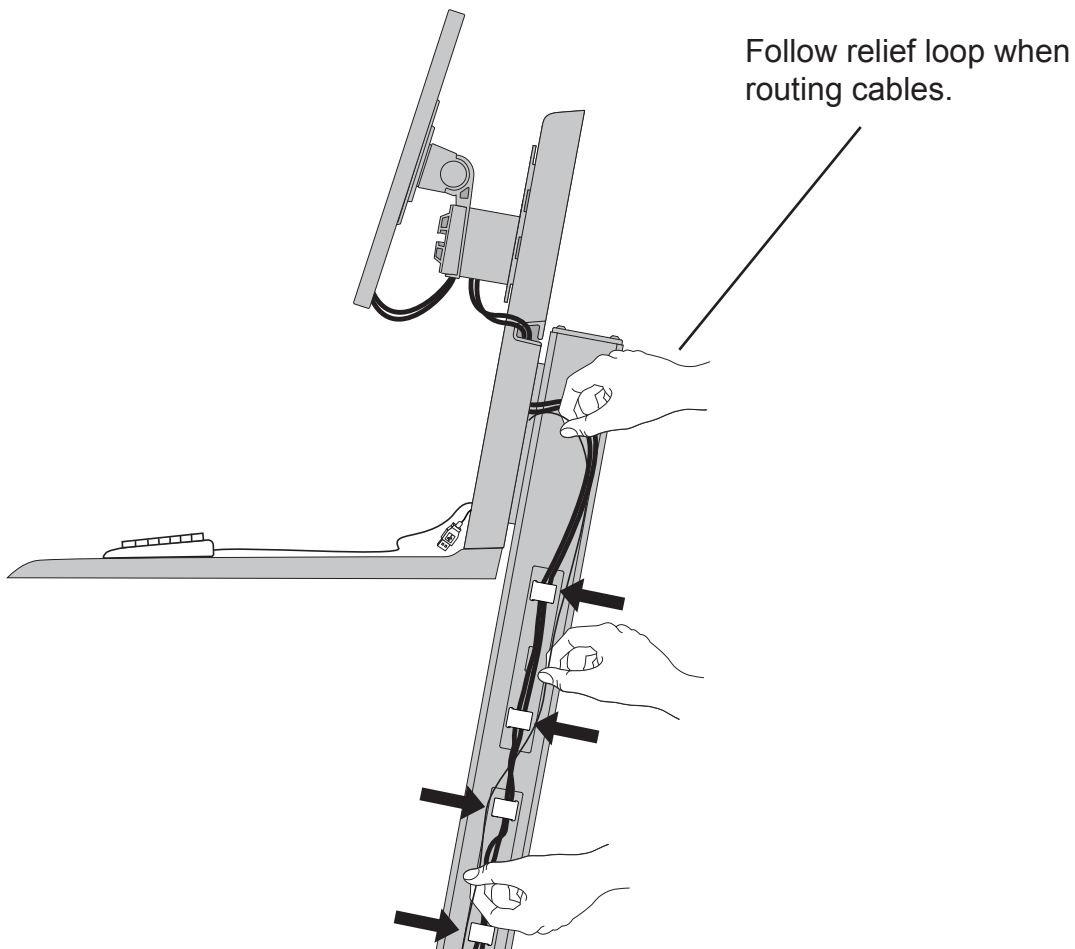

13 Adjustment Step

Important! You will need to adjust this product after installation is complete. Make sure all your equipment is properly installed on the product before attempting adjustments. This product should move smoothly and easily through the full range of motion and stay where you set it. If movements are too easy or difficult or if product does not stay in desired positions, follow the adjustment instructions to create smooth and easy movements. Depending on your product and the adjustment, it may take many turns to notice a difference. Any time equipment is added or removed from this product, resulting in a change in the weight of the mounted load, you should repeat these adjustment steps to ensure safe and optimum operation.

! WARNING
STORED ENERGY HAZARD!
DO NOT OPEN TOWER OR REMOVE SAFETY GUARD!

A primary mechanism within the tower is under tension and can be hazardous to people exposed to it under certain extreme conditions. DO NOT open the tower; DO NOT attempt to service the cart/stand. DO NOT remove safety guards or labels designed to protect or inform of possible hazards. Only Ergotron-approved installers may service or otherwise modify cart/stand. Failure to heed this Warning may result in serious Personal Injury and Damage both to the cart/stand and equipment. 822-959-00



a Lift up and down.

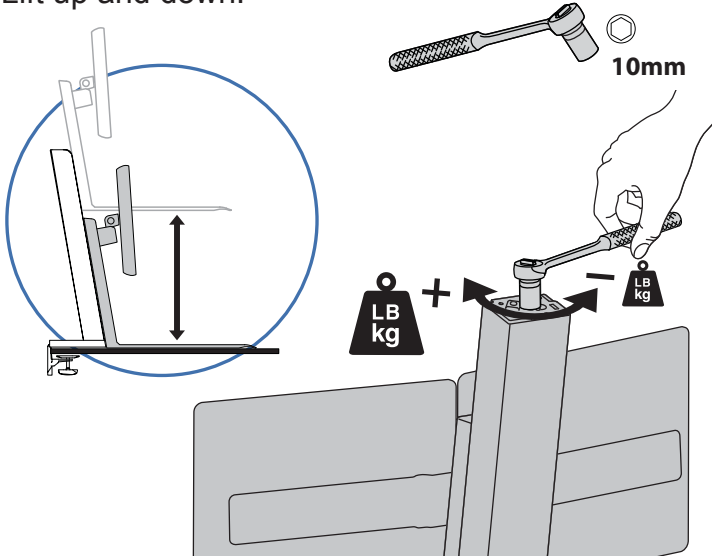

+  **Increase Lift Strength**
 If the mounted weight is too heavy or this product does not stay up when raised, then you'll need to increase Lift Strength:

-  **Decrease Lift Strength**
 If the mounted weight is too light or this product does not stay down when lowered, then you'll need to decrease Lift Strength:

b Lift up and down.

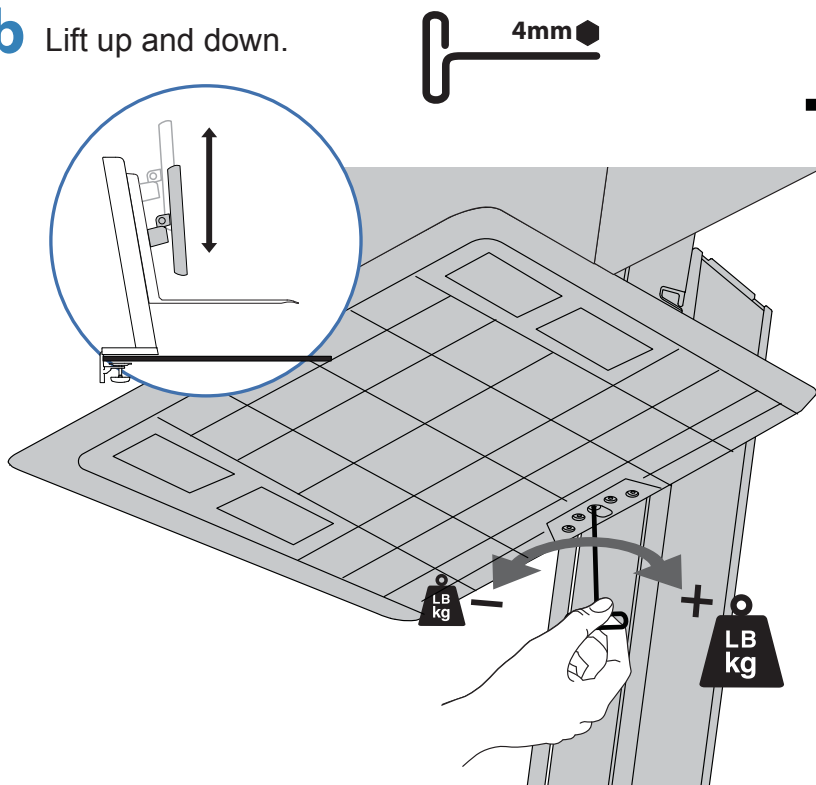

Adjustment may take up to: 72 full 360° revolutions

+  **Increase Lift Strength**
 If the mounted weight is too heavy or this product does not stay up when raised, then you'll need to increase Lift Strength:

-  **Decrease Lift Strength**
 If the mounted weight is too light or this product does not stay down when lowered, then you'll need to decrease Lift Strength:

Adjustment may take up to: 115 full 360° revolutions

C Pivot adjustment.

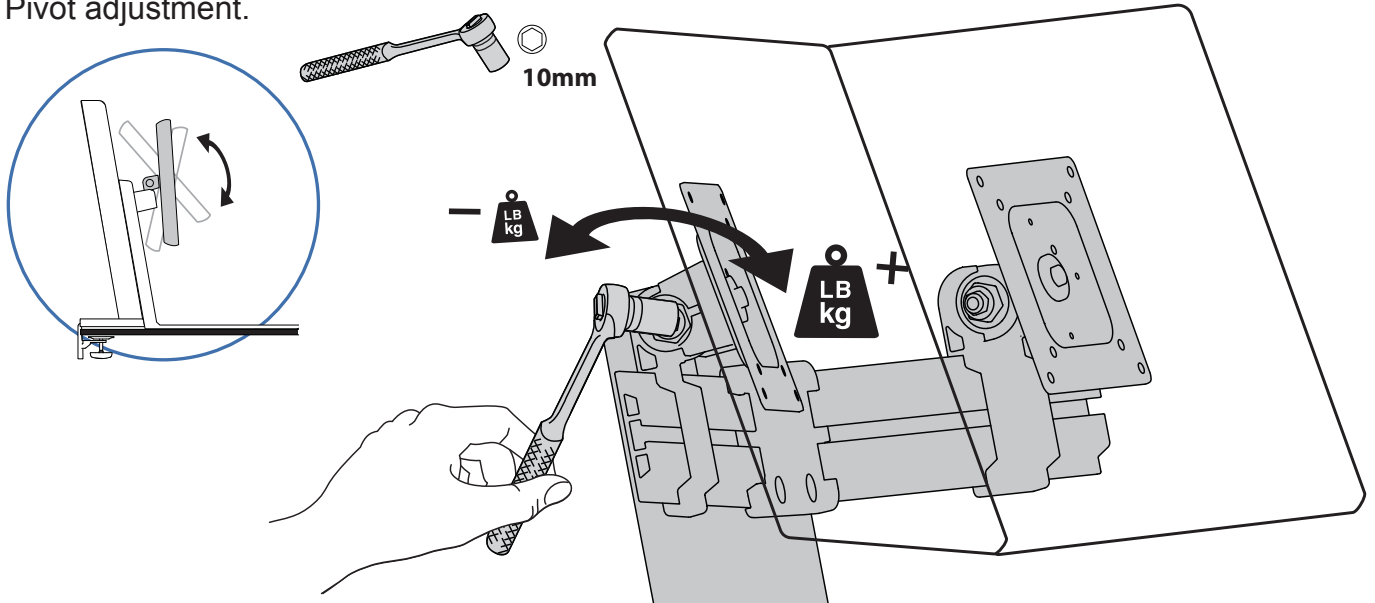

+ **LB kg**

Increase Lift Strength
If the mounted weight is too heavy or this product does not stay up when raised, then you'll need to increase Lift Strength:

- **LB kg**

Decrease Lift Strength
If the mounted weight is too light or this product does not stay down when lowered, then you'll need to decrease Lift Strength:

14 Attach caps.

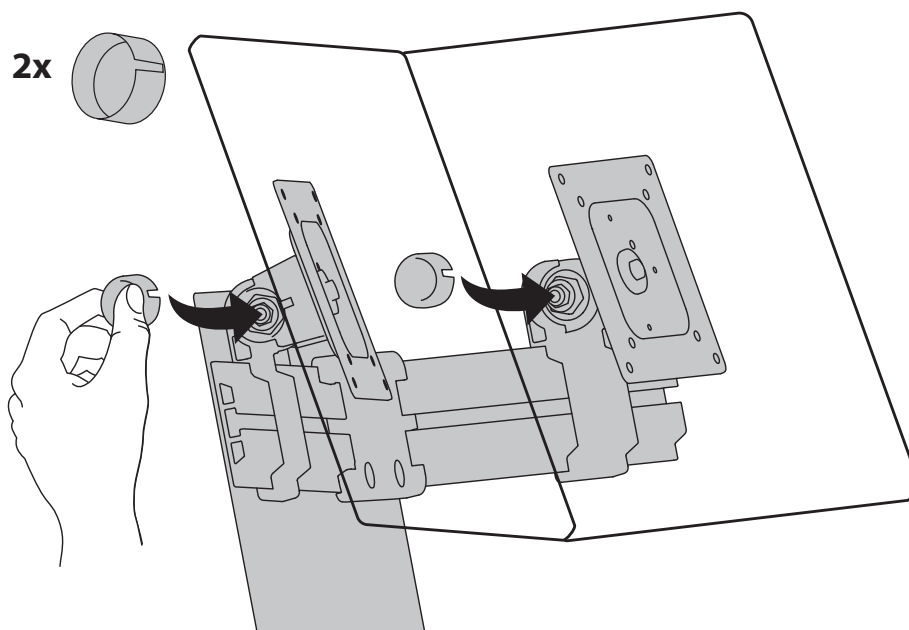

NOTE: Align slot on cap with slot in mounting bracket when installing caps.

15 Test full range of motion

a Lift riser to highest position.

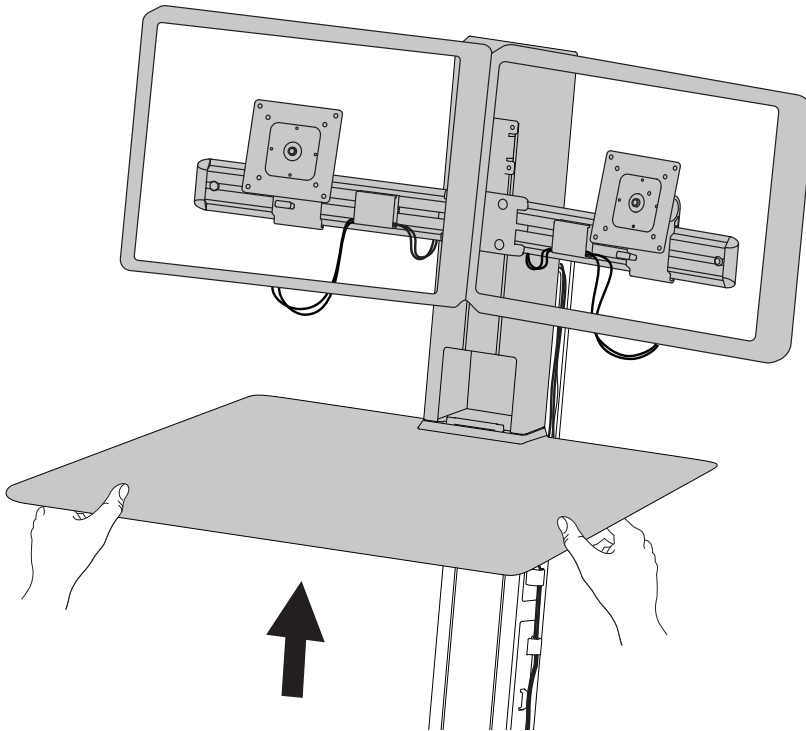

b Lower crossbar into lowest position.

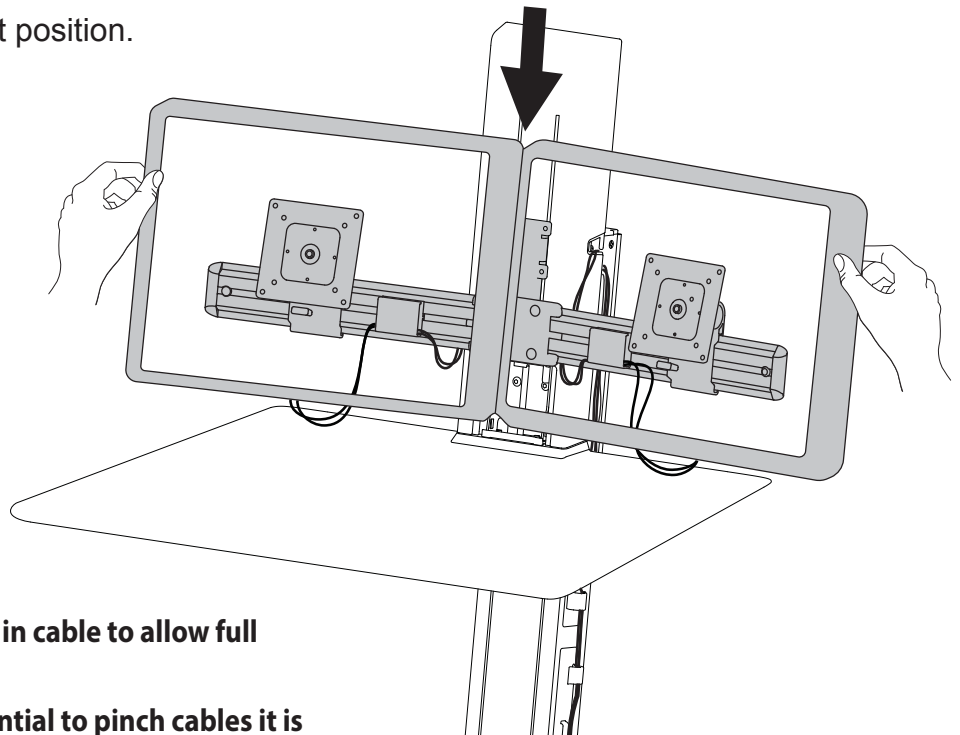

NOTE: Leave enough slack in cable to allow full range of motion.



Caution: To avoid the potential to pinch cables it is important to follow the cable routing instructions in this manual. Failure to follow these instructions may result in equipment damage or personal injury.

16

Wrap cables and fasten cable ties

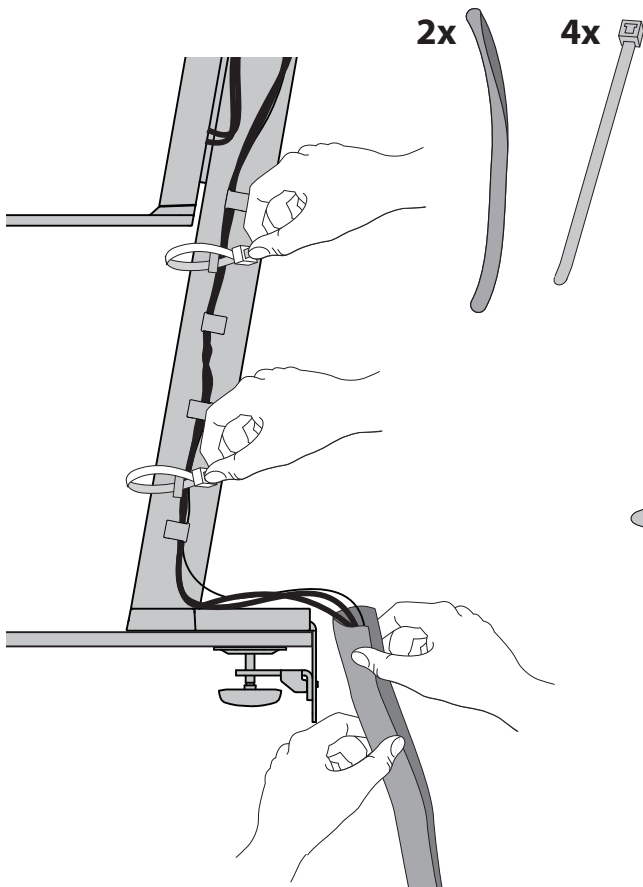

17

Attach side panels.

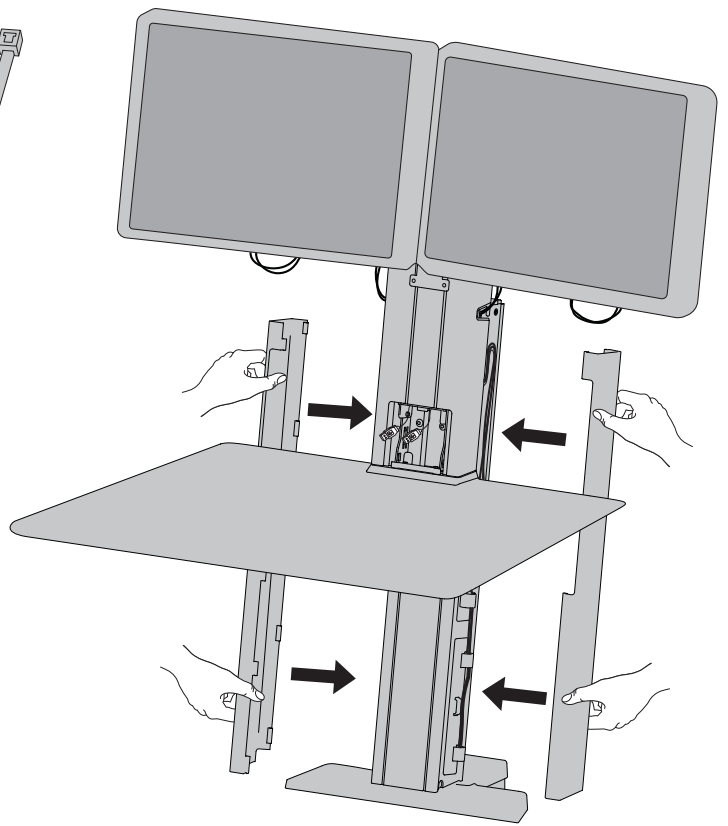

18

Attach front panel.

a

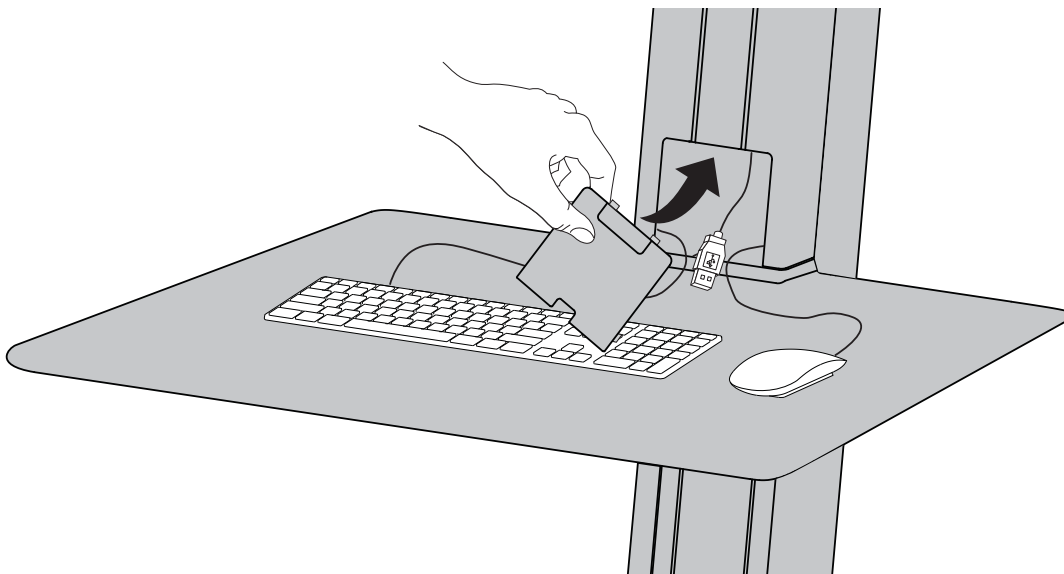

b

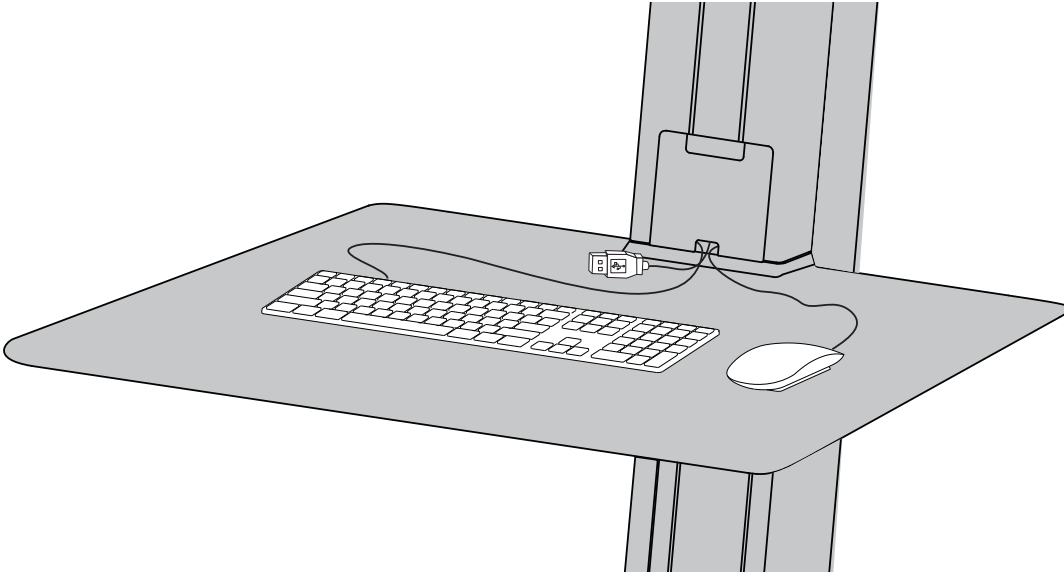

19 Attach cap to top.

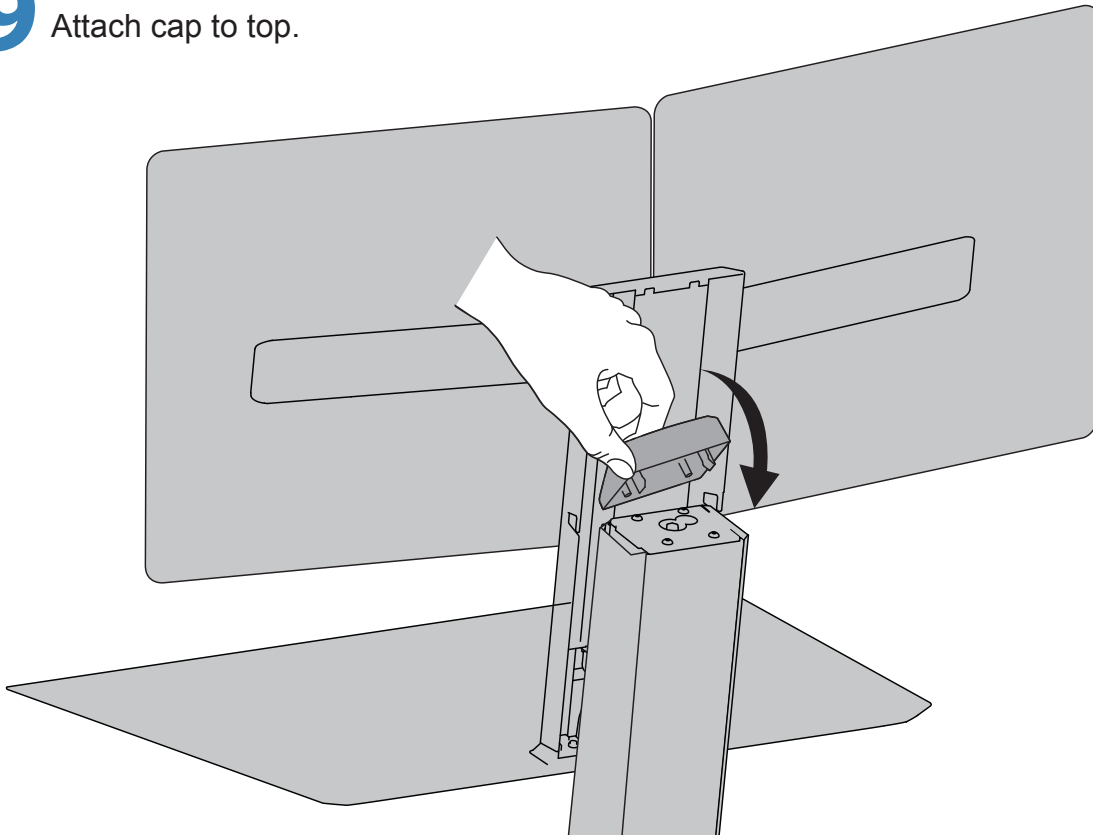

How to align worksurface to desk.

Follow these instructions if worksurface is not aligned to desk properly after installation.

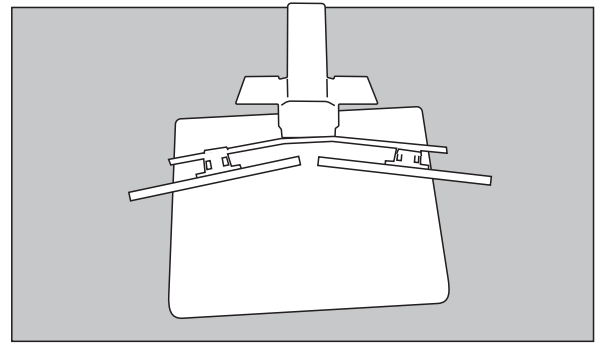

Top View

a Loosen clamp.

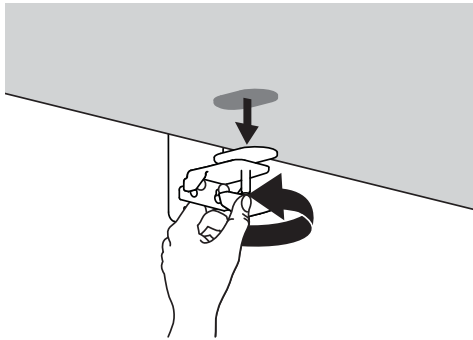

b Rotate Worfit-SR so that worksurface is parallel to front edge of desk.

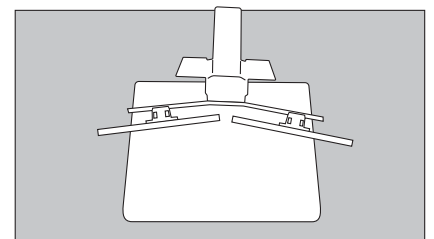
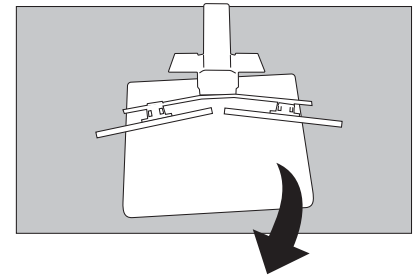
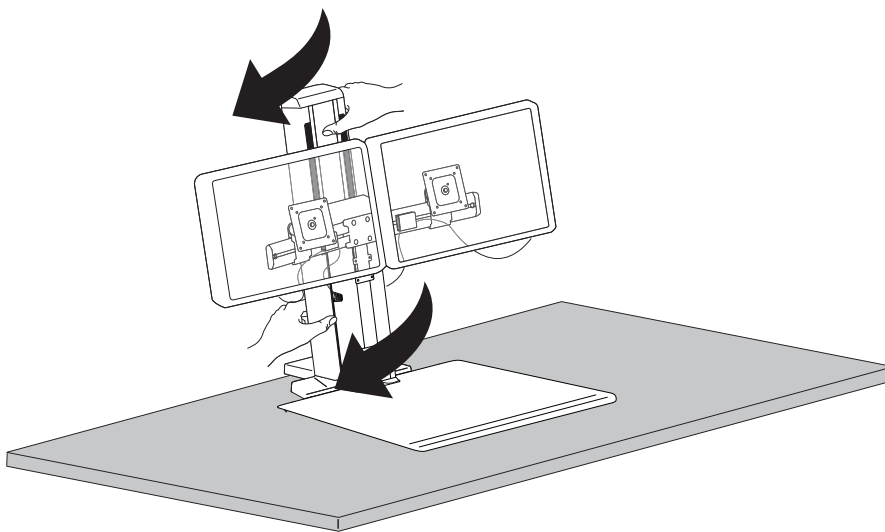

c Secure clamp to desk.

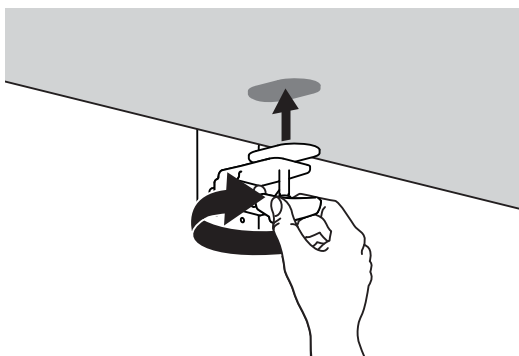

Set Your Workstation to Work For YOU!

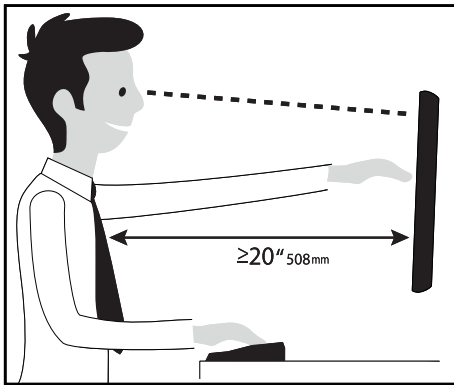

Learn more about ergonomic computer use at:
www.computingcomfort.org

- Height** Position top of screen slightly below eye level.
Position keyboard at about elbow height with wrists flat.
- Distance** Position screen an arm's length from face—at least 20" (508mm).
Position keyboard close enough to create a 90° angle in elbow.
- Angle** Tilt screen to eliminate glare.
Tilt the keyboard back 10° so that your wrists remain flat.

To Reduce Fatigue

- Breathe - Breathe deeply through your nose.
- Blink - Blink often to avoid dry eyes.
- Break • 2 to 3 minutes every 20 minutes
- 15 to 20 minutes every 2 hours.

For Warranty visit: www.ergotron.com/warranty

For Service visit: www.ergotron.com

For local customer care phone numbers visit: <http://contact.ergotron.com>

NOTE: When contacting customer service, reference the serial number.

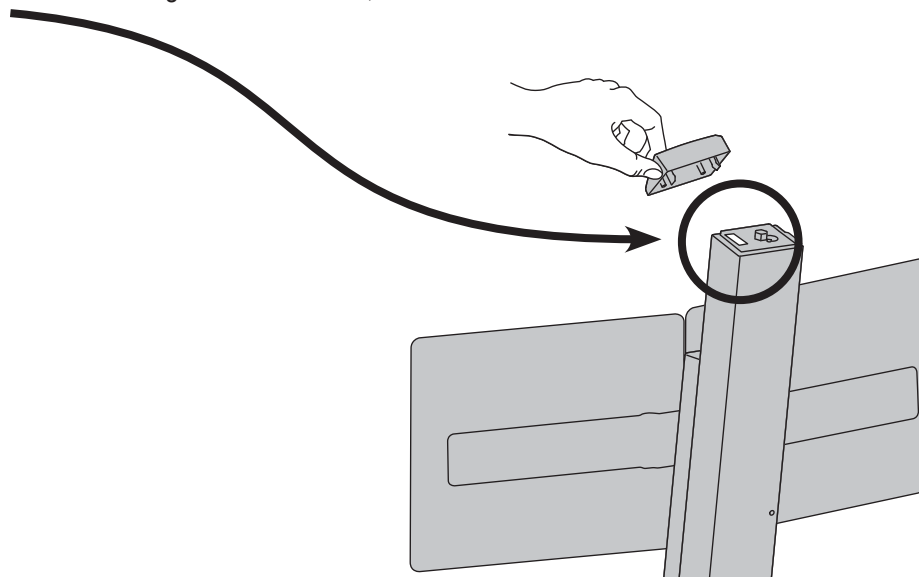

ergotron®

CF
Constant Force™

www.ergotron.com | USA: 1-800-888-8458 | Europe: +31 (0)33-45 45 600 | China: 400-120-3051 | Japan: japansupport@ergotron.com

© 2015 Ergotron, Inc. All rights reserved. WorkFit™ is a registered trademark of Ergotron, Inc.

While Ergotron, Inc. makes every effort to provide accurate and complete information on the installation and use of its products, it will not be held liable for any editorial errors or omissions (including those made in the process of translation from English to another language), or for incidental, special or consequential damages of any nature resulting from furnishing this instruction and performance of equipment in connection with this instruction. Ergotron, Inc. reserves the right to make changes in the product design and/or product documentation without notification to its users. For the most current product information, or to know if this document is available in languages other than those herein, please contact Ergotron. No part of this publication may be reproduced, stored in a retrieval system, or transmitted in any form or by any means, electronic, mechanical, photocopying, recording or otherwise without the prior written consent of Ergotron, Inc., 1181 Trapp Road, Eagan, Minnesota, 55121, USA Patents Pending and Patented U.S. & Foreign. Ergotron is a registered trademark of Ergotron, Inc.